

Revell

KIT 5633

85563300200

BELL® HUEY® GUNSHIP

The best known and widely publicized aircraft in the world is the Bell Model 204 UH-1B Iroquois. This turbine powered craft is more widely known as the "Huey Chopper". Following considerable evaluation, Bell decided that the best configuration to cope with the new requirements would be an all new turbine powered helicopter. It was designed for transport of personnel, equipment, supplies, medical evacuation, battlefield ambulance service, general utility missions and as an instrument trainer. It was this design which won the design competition in June of 1955. Appreciation is due to Bell Helicopter Co. for supplying information and data necessary to produce this detailed scale model from Revell.



Bell, Huey, emblems, logos and body designs are trademarks of Textron Innovations Inc. and are used under license by Revell Inc.



* REPEAT SEVERAL TIMES

* REPEAT PROCEDURE

* OPTIONAL PARTS

* DECAL

* ASSEMBLY CAUTION

* CEMENT TOGETHER

* REMOVE AND THROW AWAY

* DO NOT CEMENT

* A REPETER PLUSIEURS FOIS

* R P TEZ LE PROC D 

* PI CES EN OPTION

* DECAL COMANIE

* ATTENTION D ASSEMBL E

* A COLLER

* A RETIRER ET JETER

* NE PAS COLLER

READ THIS BEFORE YOU BEGIN

- * Study the assembly drawings.
- * Each plastic part is identified by a number.
- * In the assembly drawings, some parts will be marked by a star (★) to indicate chrome plated plastic.
- * For better paint and decal adhesion, wash the plastic parts in a mild detergent solution. Rinse and let air dry.
- * Check the fit of each piece before cementing in place.
- * Use only cement for polystyrene plastic.
- * Scrape plating and paint from areas to be cemented.
- * Allow paint to dry thoroughly before handling parts.
- * Any unused parts may be discarded.

DECAL APPLICATION INSTRUCTIONS

1. Cut desired decal from sheet.
2. Dip decal in water for a few seconds.
3. Place wet decal on paper towel.
4. Wait until decal is movable on paper backing.
5. Place decal in position on model, face up and slide backing away.
6. Press out air bubbles with a soft damp cloth.
7. Milkiness that may appear is for better decal adhesion and will dry clear. Wipe away any excess adhesive.
8. Do not touch decal until fully dry.
9. Allow the decals 48 hours to dry before applying clear coat.

NOTE: Decals are compatible with setting solutions or solvents.

LIRE CE QUI SUIT AVANT DE COMMENCER

- * Etudier les sch mas de montage.
- * Chaque pi ce en plastique est identifi e par un num ro.
- * Sur les sch mas de montage, certaines pi ces sont marqu es d'une  toile (★) pour indiquer qu'elles sont en plastique chrom .
- * Pour une meilleure prise de la peinture et des autocollants, laver les pi ces en plastique avec une solution d tergente peu concentr e. Les rincer et les laisser s cher   l'air.
- * V rifier que chaque pi ce s'ajuste bien avant de la coller en place.
- * N'utiliser que de la colle pour polystyr ne.
- * Gratter les parties   coller pour enlever le chrome et la peinture.
- * Laisser la peinture bien s cher avant de manipuler les pi ces.
- * Toute pi ce inutilis e peut  tre jet e.

DIRECTIVES D'APPLICATION DES AUTOCOLLANTS

1. D couper l'autocollant d sir  de la feuille.
2. Tremper l'autocollant dans de l'eau pendant quelques secondes.
3. Placer l'autocollant mouill  sur une serviette en papier.
4. Attendez que l'autocollant puisse  tre d plac  sur son support en papier.
5. Mettre l'autocollant en position sur le mod le face sur le dessus et faire glisser le support pour l'enlever.
6. Appuyer avec un chiffon doux humide pour  liminer les bulles d'air.
7. La substance laiteuse qui peut appara tre est destin e   am liorer l'adh sion de l'autocollant et devient incolore au s chage. Essuyer pour enlever tout exc dent d'adh sif.
8. Ne pas toucher l'autocollant tant qu'il n'est pas bien sec.
9. Laisser l'autocollant s cher pendant 48 heures avant d'appliquer une couche transparente.

REMARQUE: Les autocollants sont compatibles avec les solutions de fixation ou les solvants.

This paint guide is provided to complete this kit as shown on the box.

Ce guide de peinture est fourni pour reproduire le mod le r duit qui appara t sur la bo te.

Dark Brown	<i>Brun fonc�</i>
Flat Black	<i>Noir mat</i>
Flesh	<i>Chair</i>
Gunmetal	<i>Bronze</i>
Dark Gray FS 36176	<i>Gris fonc�</i>
Insignia Red FS 31136	<i>Rouge embl�me</i>
Insignia Yellow FS 33538	<i>Jaune embl�me</i>
Olive Drab FS 34087	<i>Olivet</i>
Satin White	<i>Blanc satin�</i>
Silver	<i>Argent</i>
Steel	<i>Acier</i>
Transparent Green	<i>Vert transparent</i>
Transparent Red	<i>Rouge transparent</i>

If you have any questions or comments, call our hotline at: **(800) 833-3570**
or, please write to:

Revell Inc Consumer Service Department, 1850 Howard Street Unit A, Elk Grove Village, Illinois 60007

Be sure to include the plan number (85563300200), part number, description, your return address and phone number.

Visit our website: www.revell.com

1

COCKPIT ASSEMBLY

A

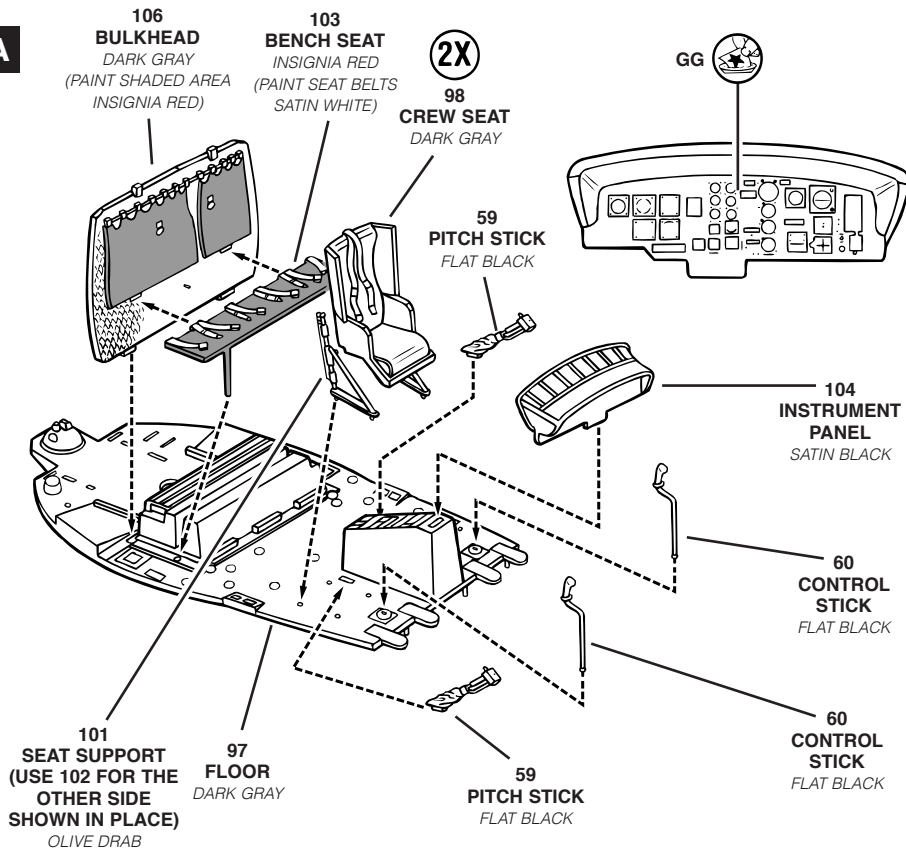

? 2X

IF PILOTS ARE TO BE INCLUDED,
ATTACH THEM TO SEATS IN THIS
STEP BEFORE THE CONTROL
STICKS ARE INSERTED

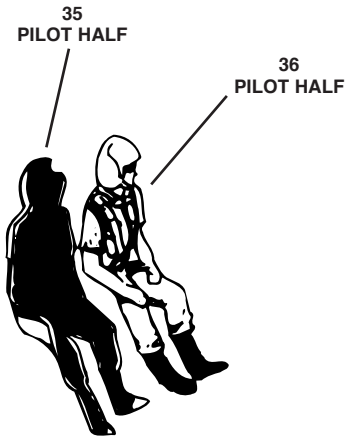

OPTIONAL PAINTING GUIDE FOR
PILOT FIGURES - PAINT FLIGHT
SUIT OLIVE DRAB, HELMET SATIN
WHITE, BOOTS DARK BROWN,
ARMS AND FACE FLESH, HOSES
FLAT BLACK, STRAPS SATIN
WHITE WITH SILVER BUCKLES
SEE DECAL PLACEMENT FOR
OPTIONAL DECALS

B

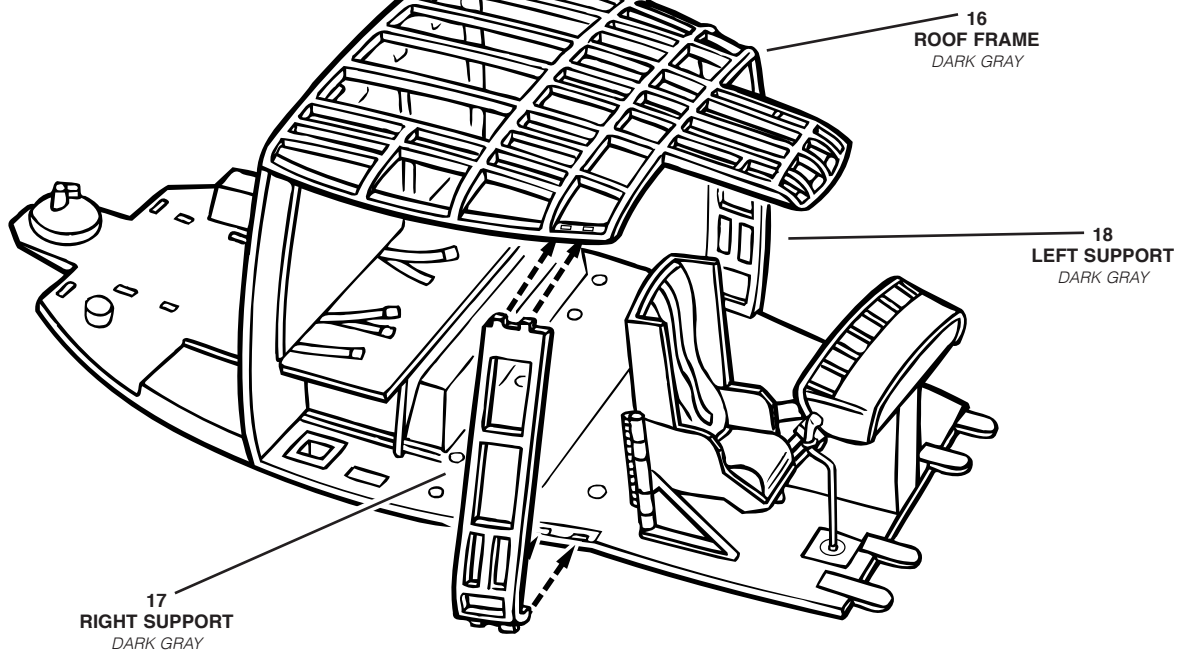

1

COCKPIT ASSEMBLY CONTINUED

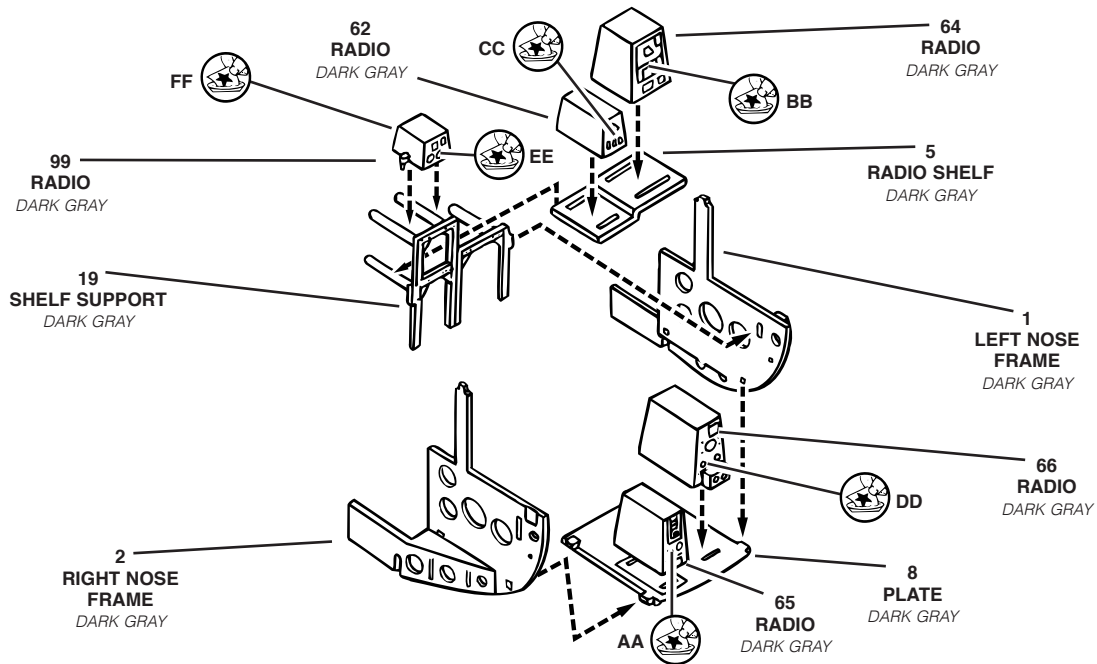
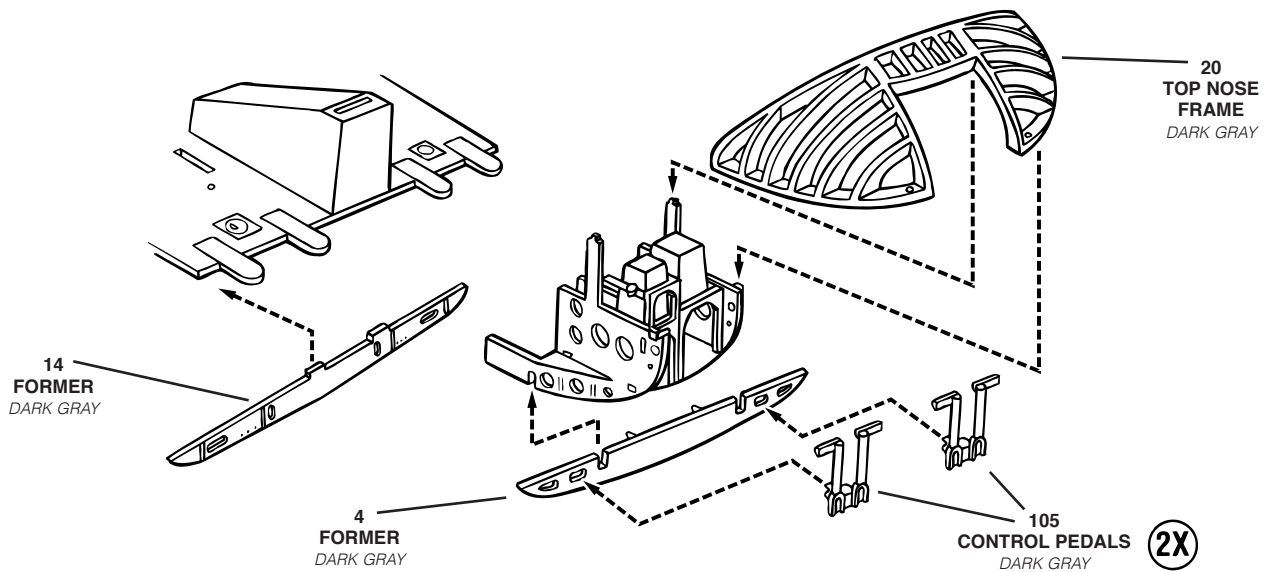
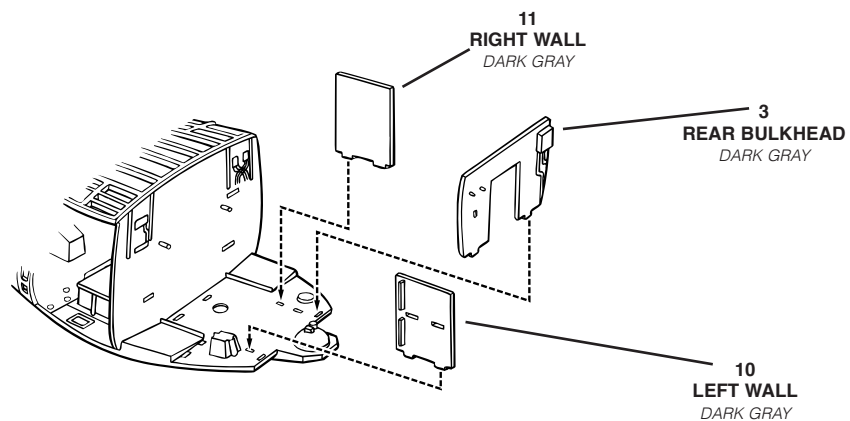
C**D****E**

2

ROTOR ASSEMBLY

A

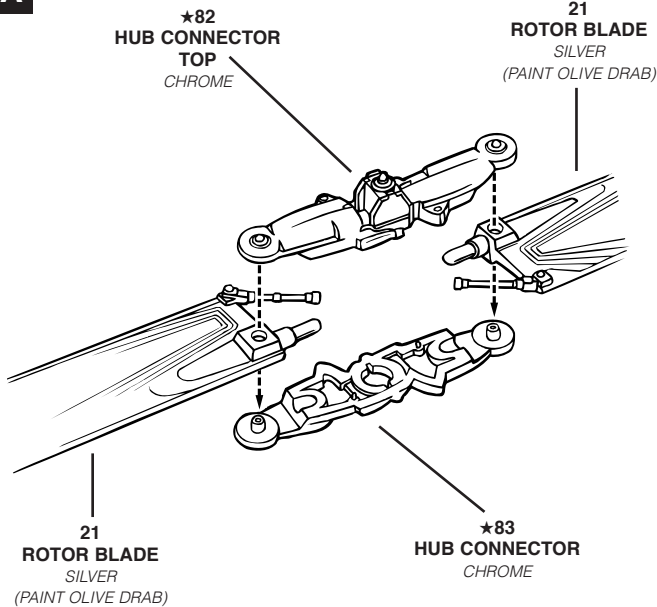

B

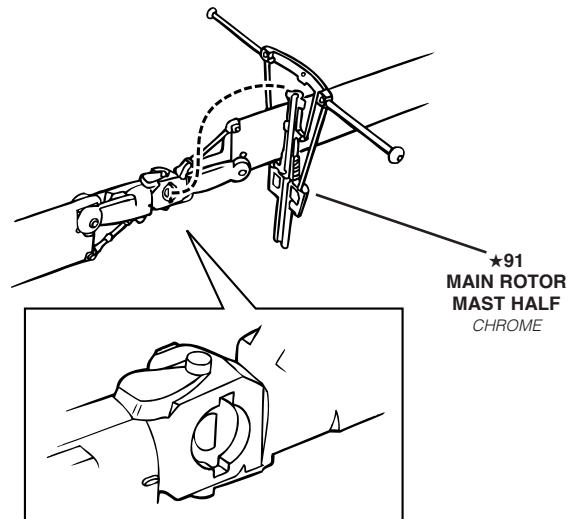

C

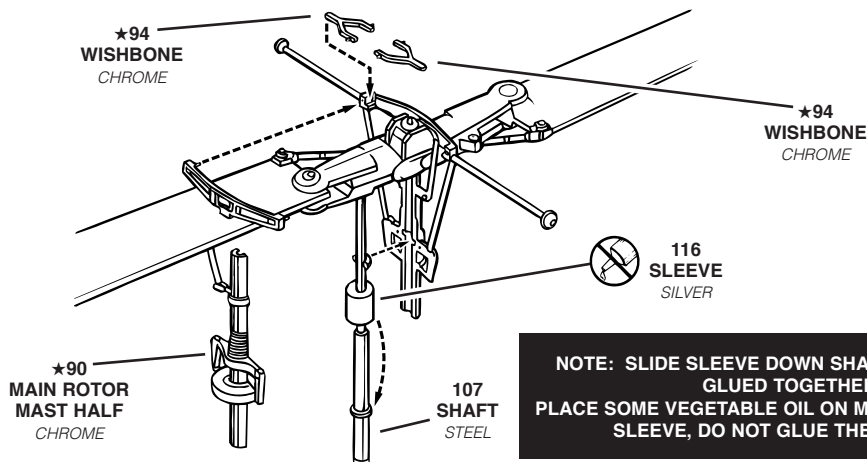

NOTE: SLIDE SLEEVE DOWN SHAFT, AFTER THE ROTOR HALVES ARE GLUED TOGETHER, SLIDE SLEEVE UP. PLACE SOME VEGETABLE OIL ON MAST FOR EASIER ROTATION WITH THE SLEEVE, DO NOT GLUE THE SLEEVE TO SHAFT OR MAST.

D

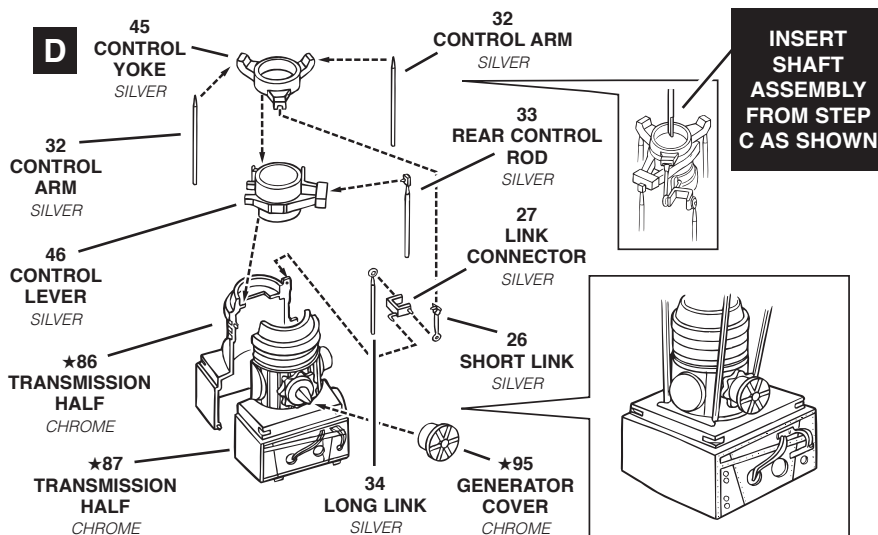

E

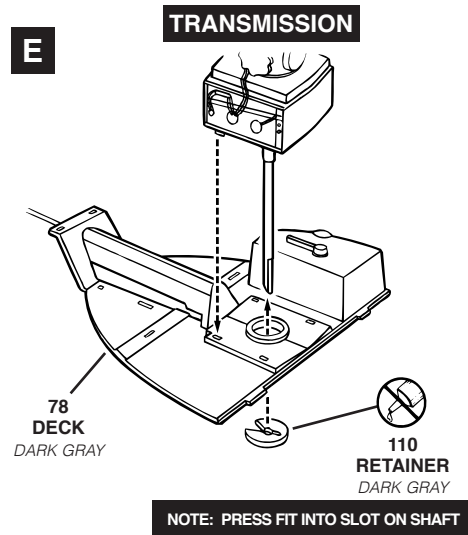

NOTE: PRESS FIT INTO SLOT ON SHAFT

3

ENGINE AND WINDOW ASSEMBLY

A

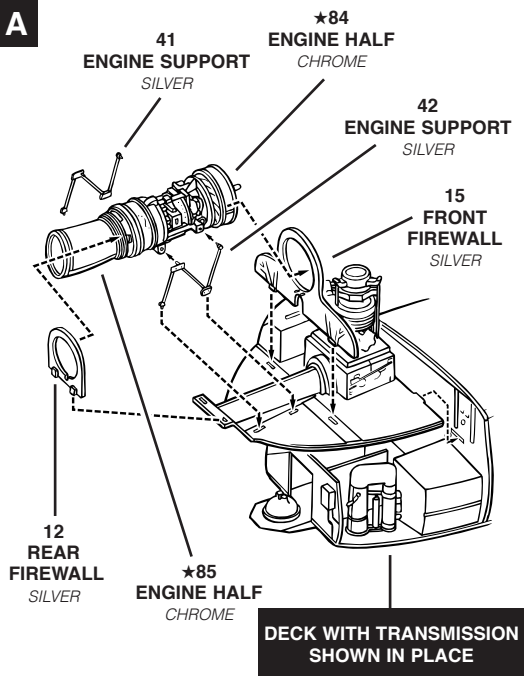

B

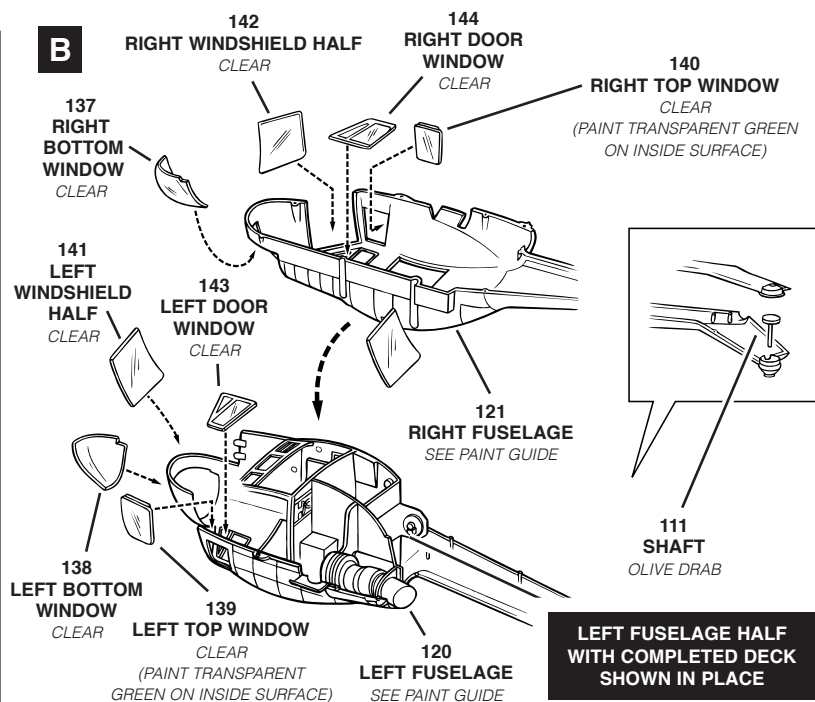

4

EXTERNAL DETAIL ASSEMBLY

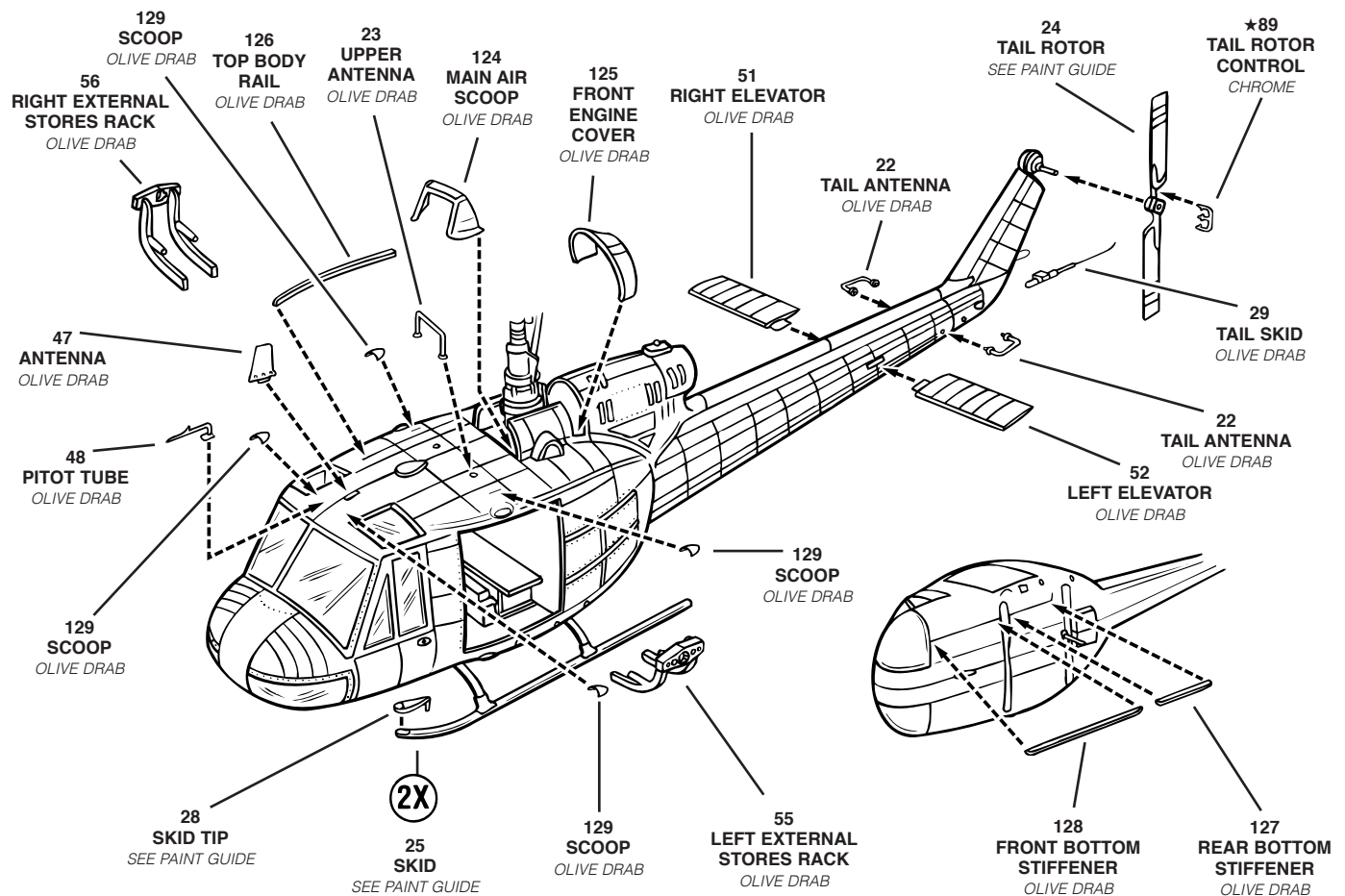

5

WEAPON AND DOOR ASSEMBLY

A LEFT SIDE

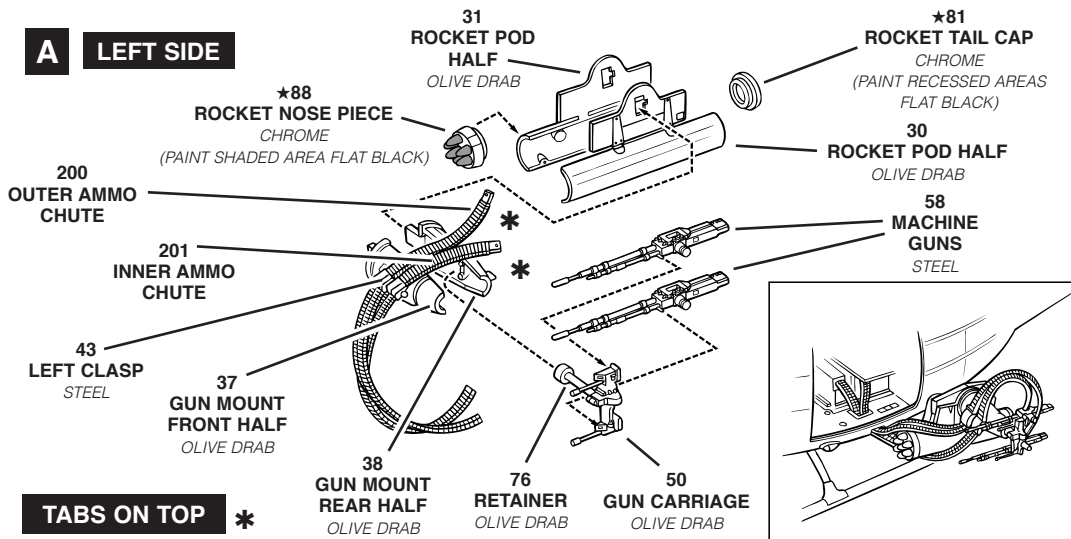

TABS ON TOP *

NOTE: BELTS FEED INTO BOX UNDER THE SEAT AS SHOWN IN THE ILLUSTRATIONS.

USE TWEEZERS AND FEED END OF OUTER AMMO CHUTE THROUGH SLOT IN LEFT SIDE OF THE FUSELAGE AND INTO FORWARD AMMO BOX. HANDLE MODEL CAREFULLY WHILE DOING THIS, SO AS NOT TO DAMAGE IT.

FEED INNER AMMO CHUTE THROUGH SLOT IN FUSELAGE AND INTO REAR AMMO BOX. CHUTE IS A SNUG FIT THROUGH SLOT IN FUSELAGE AND MUST BE PUSHED THROUGH.

PRESS REMAINING ENDS OF CHUTES INTO SLOTS IN GUNS AS SHOWN.

INSERT CHUTES ON THE RIGHT SIDE IN THE SAME MANNER AS LEFT SIDE. BOTH CHUTES FIT INTO THE REAR AMMO BOX.

B RIGHT SIDE

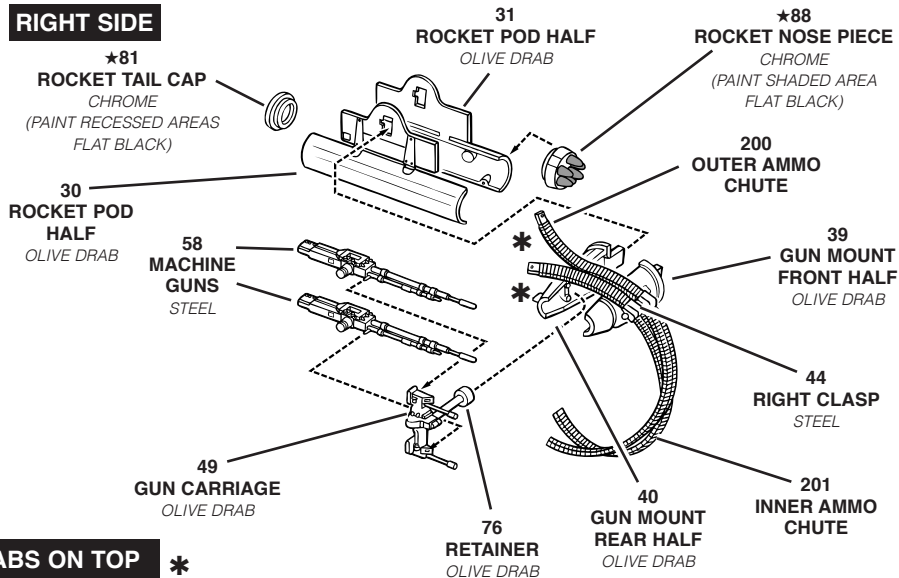

TABS ON TOP *

C

(2X)

REPEAT FOR RIGHT SIDE USING 136, 123, AND 93

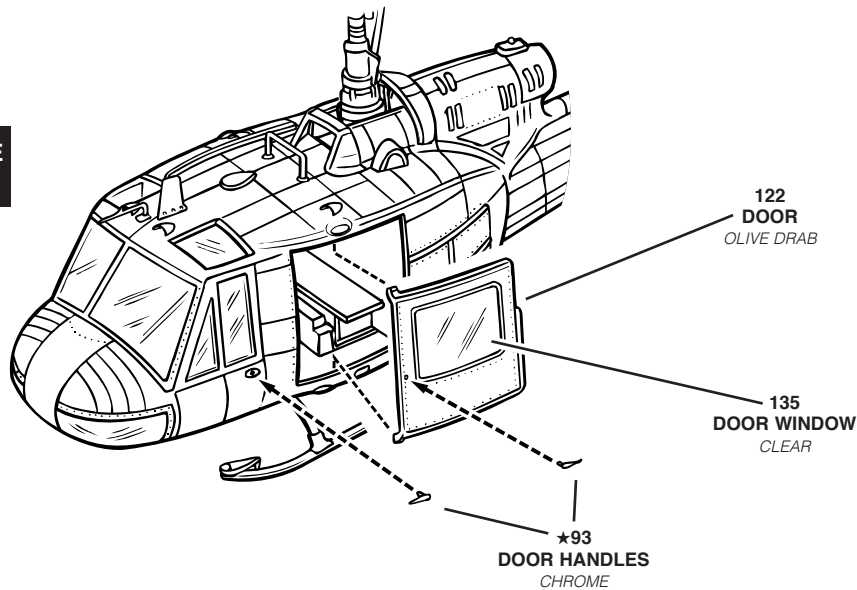

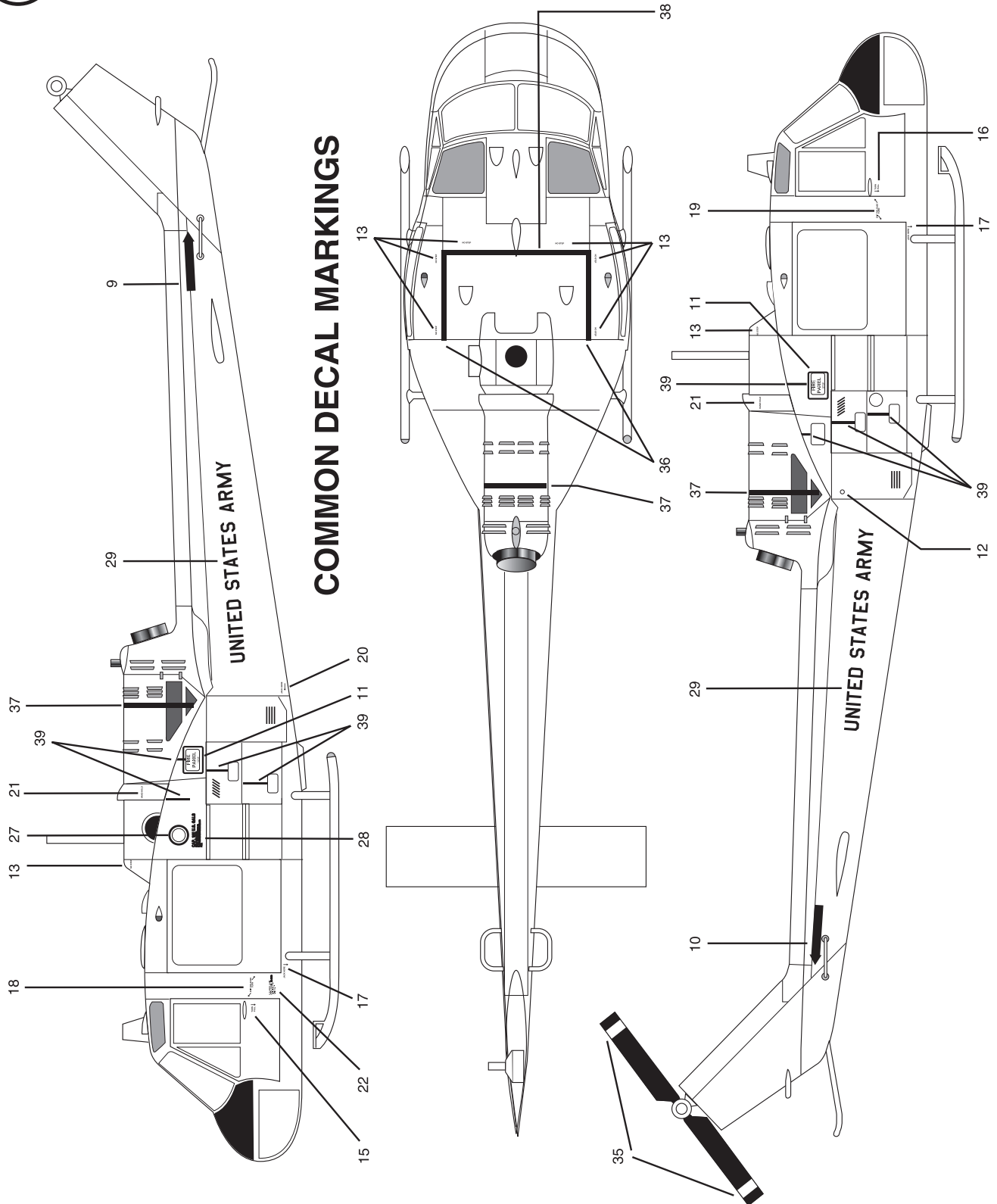



1ST AIR CAVALRY DIVISION, VIETNAM, 1966

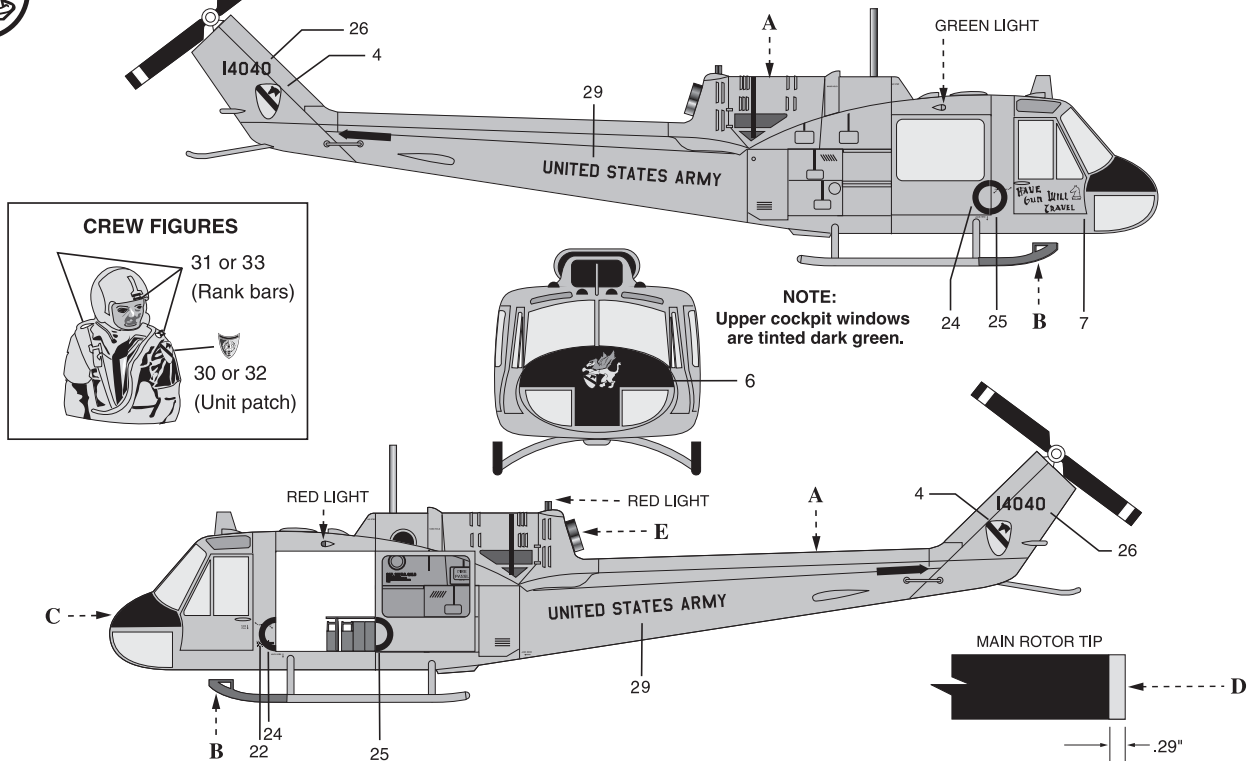

114TH ASSAULT HELICOPTER COMPANY, VIETNAM, 1966

