

# INFO **EDUARD**

Vol 17, March 2018

ISSUE 94



price US \$ 0.00



**Fw 190A-5  
NEW TOOL.  
1/48**



# INFO EDUARD

ISSUE 94



© Eduard - Model Accessories, 2018

FREE FOR DOWNLOAD, FREE FOR DISTRIBUTION!

This material may only be used for personal use. No part of the text or graphic presentations can be used in another publication in any other media form or otherwise distributed without the prior written permission of Eduard - Model Accessories and authors involved.

Editorial and Graphics - Marketing department, Eduard - Model Accessories, Ltd.



**MARCH 2018**

# CONTENTS

**EDITORIAL - 4**

**KITS - 8**

Fw 190A-5 light fighter ProfiPACK 1/48  
Fokker D.VIII ProfiPACK 1/48  
Avia Bk.534 Graf Zeppelin Weekend Edition 1/72  
Riders in the Sky 1944 Limited edition 1/72

**HISTORY - 25**

Preview of the book  
Riders in the Sky 1944

**BRASSIN - 30**

**PHOTO-ETCHED SETS - 38**

**BIGED - 45**

**RELEASE - 44**

March 2018

**BUILT - 46**

Fw 190A-5 light fighter 1/48  
Fokker D.VIII 1/48  
Riders in the Sky 1944 1/72  
MERSU 1/48  
Bf 109G-14 1/48

**ON APPROACH - 54**

April 2018



# EDITORIAL

Dear Friends,

March is the month when many of our centres of attention from Nuremberg hit the market. Today marks the official availability of our 1:48 scale Fw 190A-5 and the 1:72nd scale Limited Edition Riders In The Sky, the subject of which is the Liberator GR.Mk.V (with the GR. Mk.III also represented). Details on this subject can be gotten later in this newsletter and if it's not enough for you, go to our Facebook page. Over the past couple of weeks we have posted an enormous amount of information about these kits and you'll find all the information there you could possibly need. If you still have any questions, please feel free to write us. We answer any and all questions on the matter. I am happy to answer your questions myself and do so as often as I can. What you may not find out from the Facebook posts is that these kits will be accompanied by a slew of offers to the BFC members. This will include an expanded assortment of markings options and will include Liberator Mk.V BZ780 with which the well known pre-war boxer and No.311 Squadron member Vilem Jaks perished. This is something aimed purely at the Czech market, with possible Slovak interest as well. Most of the Libs in the package are the same same, the main differences being the serial number and aircraft letter. This generally applies to the entire RAF, but all of the thirteen aircraft that are depicted in the kit have an extremely interesting history to tell.

The BFC offering for the Fw 190A-5



will garner a higher level of attention internationally and will be a more involved item. This will include cannon pods in resin, and will include only one marking option, though it will be the interesting and well known aircraft flown by Lt. Hosum of 2./JG 11 from April, 1943. This BFC item will be a bit more expensive than the typical offering, but given its attractiveness and layout, I think this will be considered justified. Both of the BFC items will become available in all likelihood in April, and there will be certainly more to write about in that month's newsletter. The March assortment of BFC items is also expanding, and this by the BF 109G-14 of Erich Hartmann as it appeared in January, 1945 when the aircraft was flown by Uffz. Anton Kellmayer, a member of 7./JG 52 based at Babolnapuszta in Hungary. Technically, it was no longer Hartmann's machine, but it gain in appearance by the addition of an emblem on the engine cowl and a yellow V identifier on the wing.

After a very long absence, we are putting the 1:48th scale Fokker D.VIII back in circulation in March, earlier offered as the Fokker E.V. The only modification to this relates to the markings options. First and foremost, this covers the lozenge pa-

tern, an integral part of most of the options in the kit. The colours of the hexagons have been brought to conform with the latest information uncovered. The final of the kits for the month is the Weekend Edition of the Avia Bk.534 in 1/72nd scale. This kit is dedicated to one of the more famous of uses of the type, that as a testbed for landing equipment for aircraft being planned for the aircraft carrier Graff Zeppelin.

In March, we are preparing a significant event connected to the new MiG-21MF. A while back I committed to attending a contest at Prostejov and to prepare a preproduction kit of the new MiG-21 that would be available there. And if we were committed to making such a kit, it would be available to all those that were interested with the condition that they attend the show to pick the kit up personally and so become the first modellers to win the model. Those that order the kit by mail won't be able to get theirs until the beginning of April. The model will be very specific in many ways, such as it will not include a tree with weapons because these will not meet the deadline for the show. To compensate, Brassin pylons and rockets will be included instead. The decal sheet will be downgraded to offer a single marking option and an instrument panel with side consoles. There will also be a limited number of stencil data on this sheet. The kit will include masks but no photoetched. In all, this may paint this version of the kit in an unfavourable light, but I would suggest waiting to see the actual item before passing judgement on it.

As far as accessory sets that go on sale today are concerned, I would point out the collection of brass items for the B-2A where first and foremost the wheel wells and bomb bay are covered. A very comprehensive collection of four photoetched sets and a mask set are available for ICM's He 111H-3 in 1:48th scale.

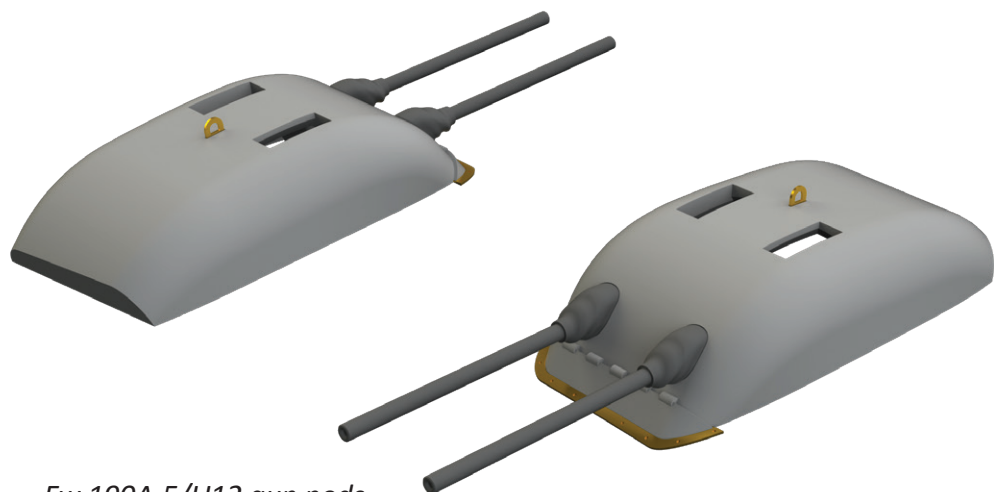

*Fw 190A-5/U12 gun pods*



As usual, we are also releasing sets for our own kits that coincide with the introduction of said kits. This applies to the Liberator as well as the Fw 190A-5 in the form of photoetched and Brassin items. In both cases, these are certainly significant items as far as this month's releases are concerned. However, the more interesting Liberator items are due to arrive in April. These will include the superchargers, bomb bay doors and retractable rocket rails that were carried in the bomb bay. Renders of these items can be found in the section of forthcoming items below.

As of today, we are selling paints by Mission Models. For now, only in the Czech Republic and only at the retail level. The reasons for taking on this line can be listed, as there are several. As an example, they have no strong odour, despite not being water colours by any means, and being ammonia based. They are intended to be diluted with a specific thinner. They are water soluble and we recommend using water only for the cleaning of your airbrush. There is a specific thinning formula that uses less thinner than paint. The paints include a dropper so that the procedure is greatly streamlined. Actually,



the use of these paints is very user friendly. The paints are safe to use, non-flammable, and can be shipped by air allowing for easier and regular restocking. The tones look very good and there is a good assortment of shades available in this growing range. Our next shipment will already include new items. I have nothing but good to say about these paints, but what do you expect when I decided i wanted to carry this line? I invite you to try them out and decide for yourself.

I hope to see some of you at Pro-sek which is coming up fast. Keep an eye on our Facebook page which will give you more information than here. March will be an interesting month to watch us from there.

Happy Modelling  
Vladimir Sulc

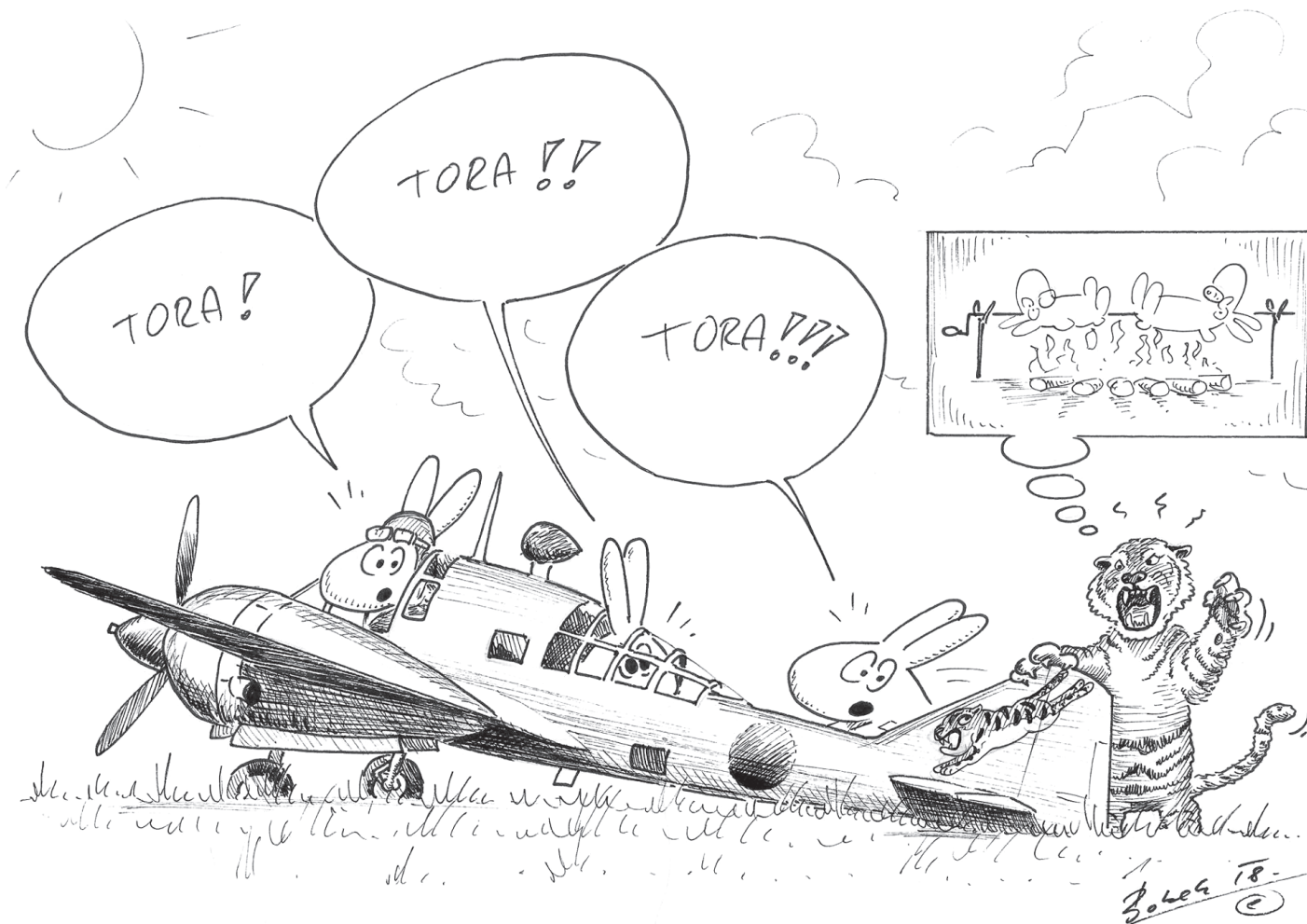



eduard

2018



1/72



MiG-21MF

LIBRARY EDITION

PREORDERS

1st PREMIUM RUN - 6 - 15 March 2018

2nd RUN - 21 - 31 March 2018

KITS WILL DISPATCH 2 - 6 APRIL 2018



WWW.EDUARD.COM

Cat.No. 2124



# MISSION MODELS

PREMIUM HOBBY PAINTS, PRIMERS & ADDITIVES

CHANGE  
THE  
WAY  
YOU  
PAINT



[WWW.MISSIONMODELSUS.COM](http://WWW.MISSIONMODELSUS.COM)



# Fw 190A-5 light fighter

# 1/48

**ProfiPACK**  
edition



## 1/48, Cat. No. 82143

- plastic parts Eduard
- photo-etch set
- painting mask
- decals Eduard
- 5 markings

[Product Page](#)

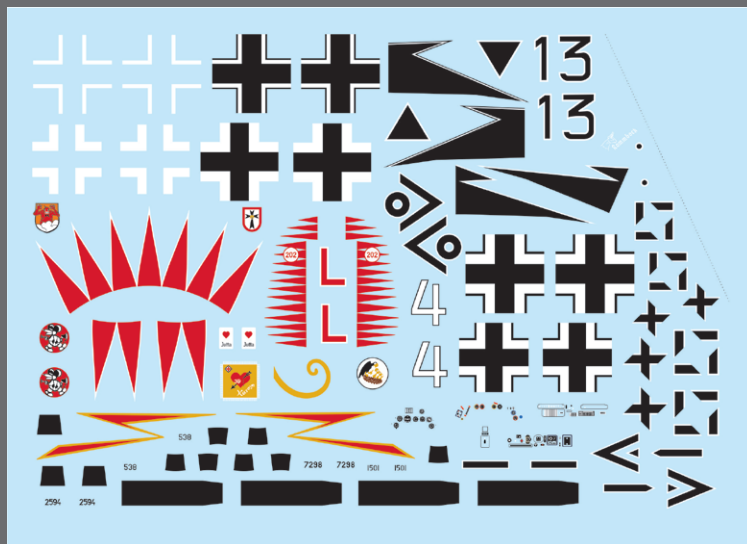

## RECOMMENDED:

- 48949 Fw 190A-5 1/48 (PE-Set)
- 48950 Fw 190A-5 landing flaps 1/48 (PE-Set)
- 648356 Fw 190A wingroot gun bays 1/48 (Brassin)
- 648366 Fw 190A propeller 1/48 (Brassin)
- 648371 Fw 190A control surfaces early 1/48 (Brassin)
- 648373 Fw 190A Pitot tubes early 1/48 (Brassin)
- 648381 Fw 190A exhaust stacks 1/48 (Brassin)
- 648390 Fw 190A-5 cockpit 1/48 (Brassin)
- 648391 Fw 190A-5 engine 1/48 (Brassin)
- 648392 Fw 190A-5 fuselage guns 1/48 (Brassin)

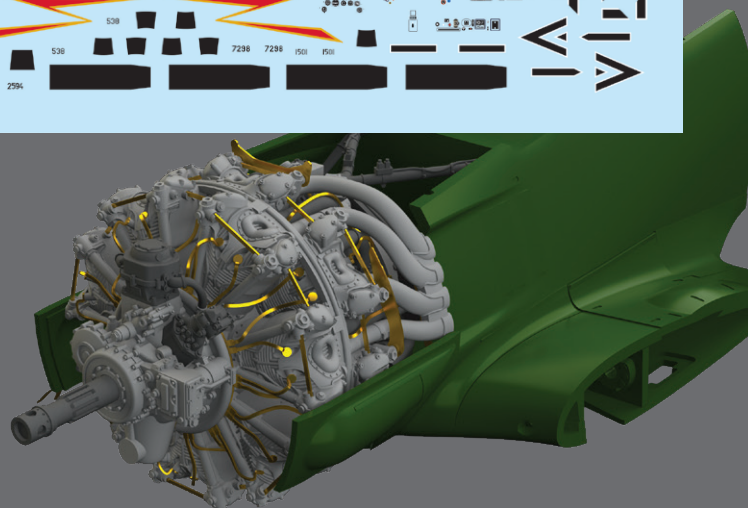



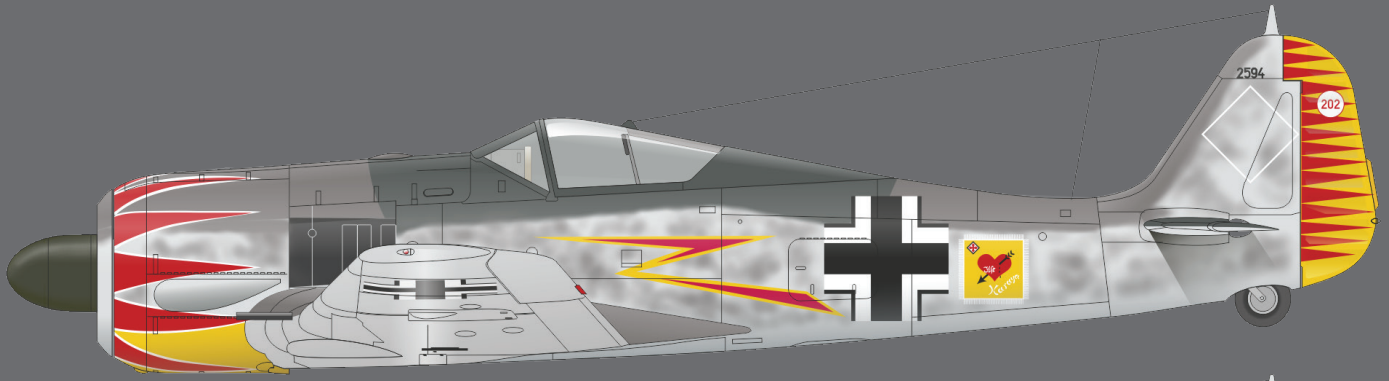

W. Nr. 0152 594, Maj. Hermann Graf, CO of JGr. Ost,  
Toulouse – Blagnac, France, April 1943

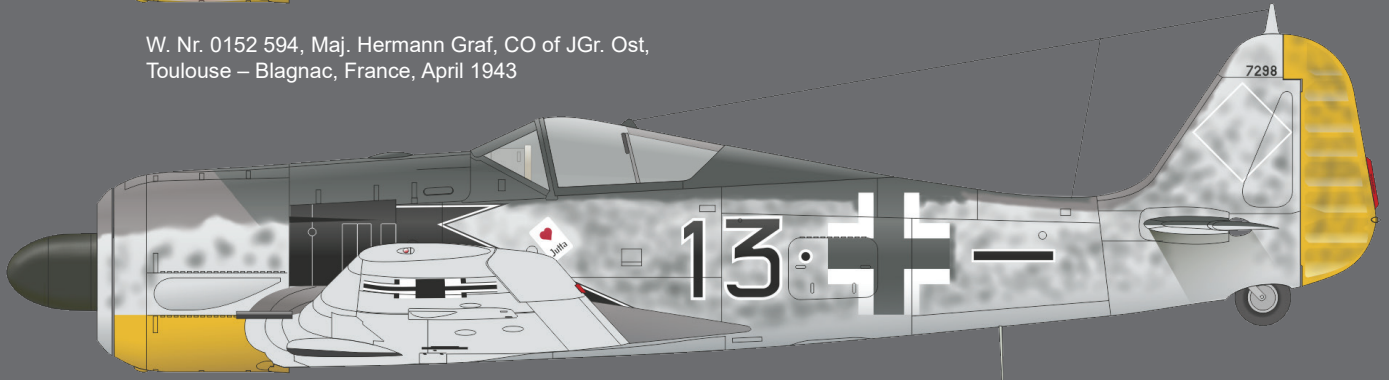

W. Nr. 0157 298, Maj. Josef Priller, CO of JG 26,  
Lille - Vendeville, France, May 1943

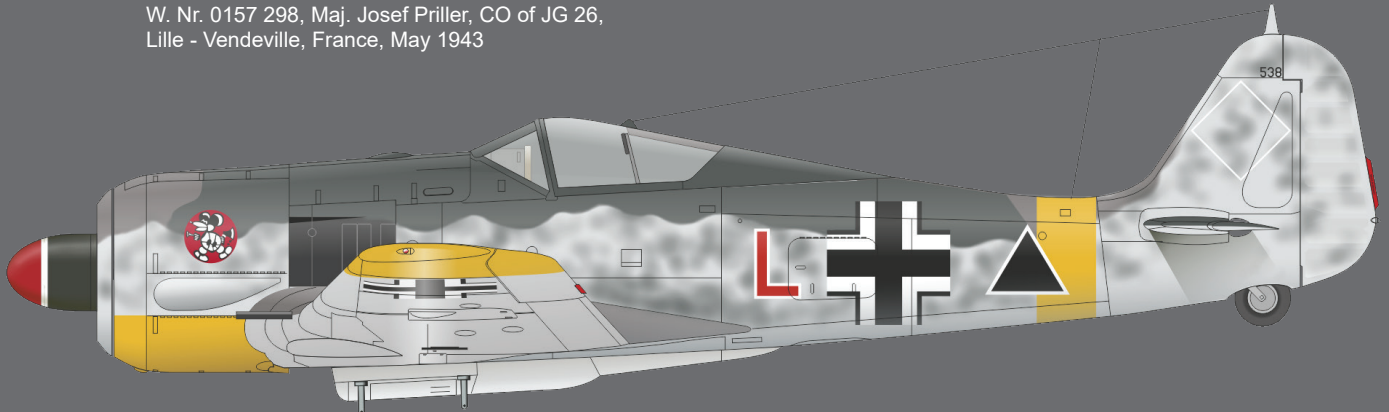

W. Nr. 538, 6./Schl.G 1, Deblin - Irena, Poland , January 1943



W. Nr. 1501, Oblt. Walter Nowotny, CO of 1./ JG 54, Orel,  
Soviet Union, Summer 1943

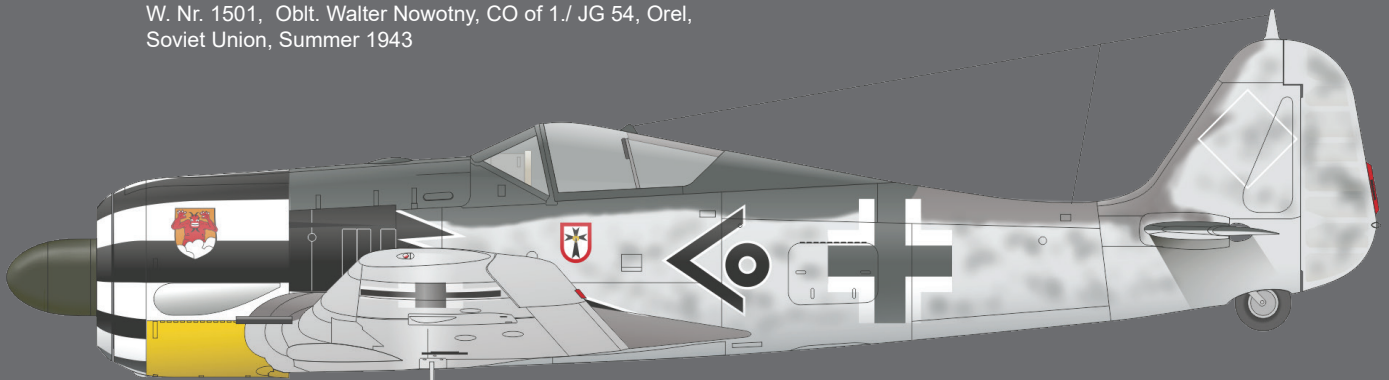

Oblt. Rolf Strohal, Stab I./JG 1, Deelen, the Netherlands, April 1943



# Fw 190A-5 light fighter

## 1/48



built by Petr Zatřepálek

Camo D





## W. Nr. 0152 594, Maj. Hermann Graf, CO of JGr. Ost, Toulouse – Blagnac, France, April 1943

Hermann Graf, although flying with the Luftwaffe already from the start of the Second World War, didn't fly combat until operations over Crete. His first combat victories were achieved over the plains of the Soviet Union with JG 52. He was very successful, and in the space of thirteen months, he would amass 202 kills over Soviet aircraft. On September 16th, 1942 he was awarded Germany's highest honour, the Knight's Cross with Oak Leaves, Swords and Diamonds. After that, he was withdrawn from combat and made CO of the training unit JGr.Ost. After a short stint with JG 50, he was made CO of JG 11 on November 11th, 1943, and on October 1st, 1944, he stepped into the same role with his former JG 52, which he would lead up to the end of the war. After the war, the Americans turned him over to the Soviets, who would not release him until December 25th, 1949. Hermann Graf died on November 4th, 1988 in Engen.

Hermann Graf flew two aircraft while serving with JGr.Ost, an Fw 190A-4 and an Fw 190A-5. The aircraft carried a red tulip motif on the yellow engine cowl, with a similar design being carried on the rudder with a scoreboard of his kills. Graf's personal marking appeared on the rear fuselage on the left side, while the unit badge of an eagle teaching her young to fly appeared on the right side.

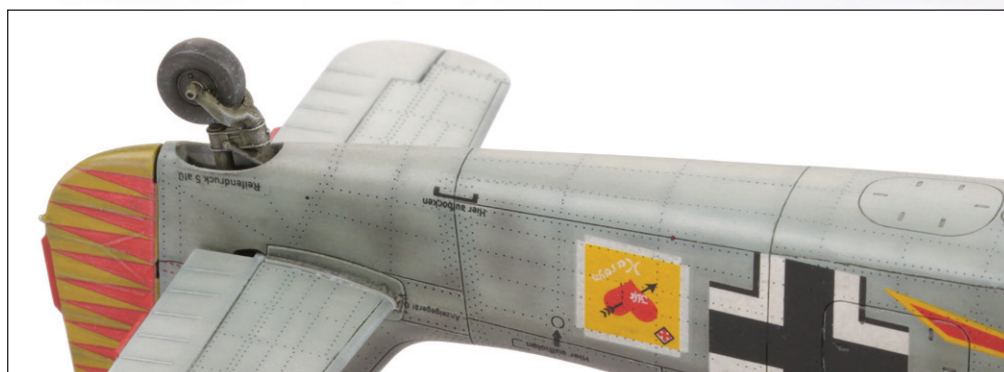
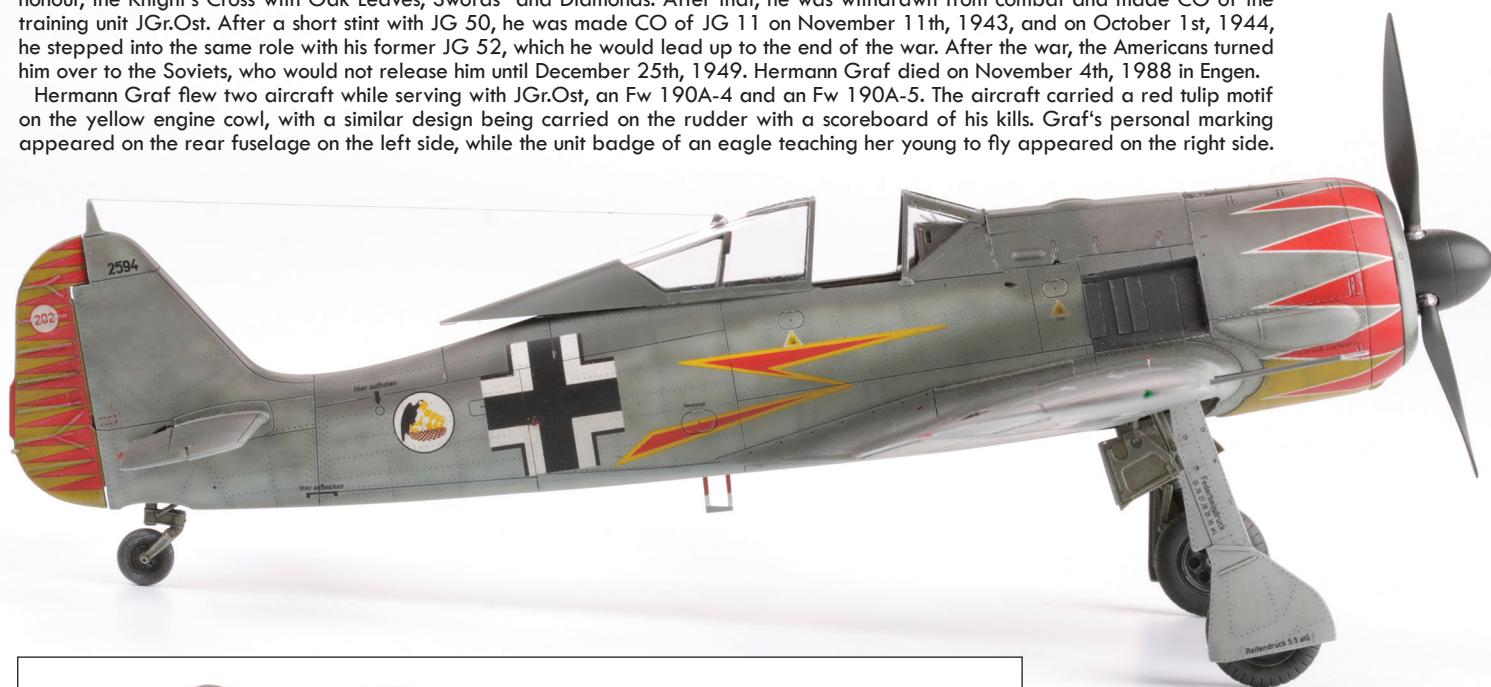

[Product Page](#)

Cat. No. 82143





# Fw 190A-5 light fighter

## 1/48



built Jakub Nademlejnský

Camo B





## W. Nr. 1501, Oblt. Walter Nowotny, CO of 1./ JG 54, Orel, Soviet Union, Summer 1943

A German fighter pilot of Austrian decent and a native of Gmünd situated near the border with Czechoslovakia, Walter „Nowi“ Nowotny was a holder of the Knight's Cross with Oak Leaves, Swords and Diamonds, and shot down 258 enemy aircraft over the course of 442 combat sorties. He was killed in an Me 262 Schwalbe in combat with American escort fighters near an airfield at Hesepe on November 8th, 1944.

"Nowi's" aircraft got a non-standard camouflage consisting of two shades of dark green, most likely RLM 70 and its combination with another colour. The yellow wingtips of the undersides and yellow band round the fuselage identified the aircraft flying in the Eastern Front. The JG 54 aircraft bore yellow band on the fuselage, underneath the fuselage crosses, and bottom part of the rudder was painted yellow as well. The front part of the propeller spinner bore, most likely, yellow spiral. Underneath the cockpit there was a private symbol of the pilot.

Product Page

Cat. No. 82143





# Fokker D.VIII

# 1/48

## ProfiPACK edition



### 1/48, Cat. No. 8085

- plastic parts Eduard
- photo-etch set
- painting mask
- decals Eduard
- 5 markings

[Product Page](#)

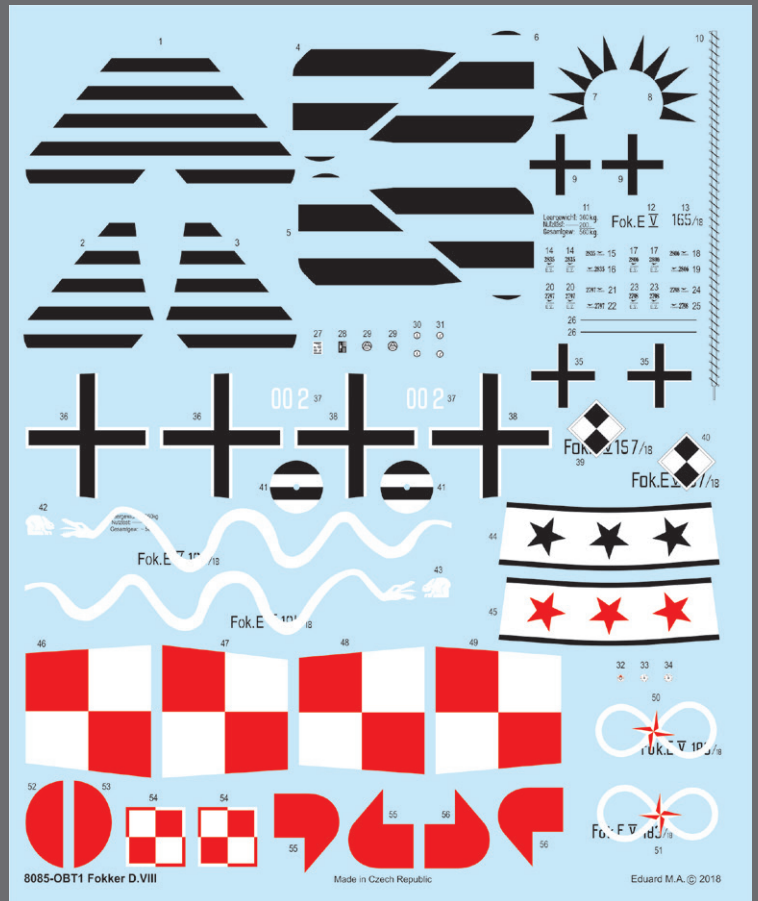
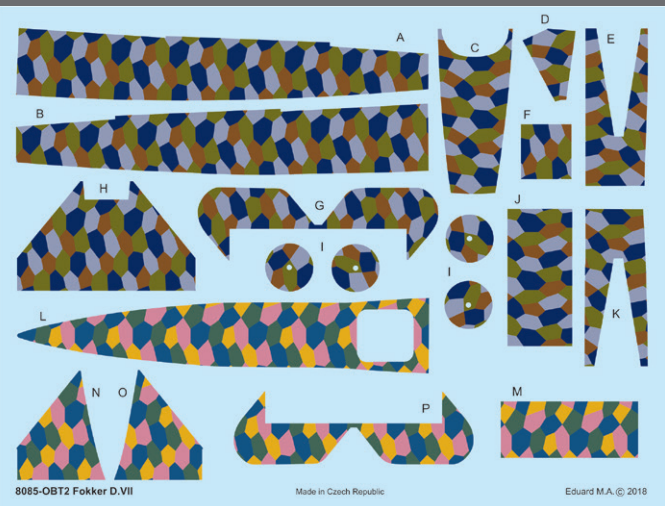



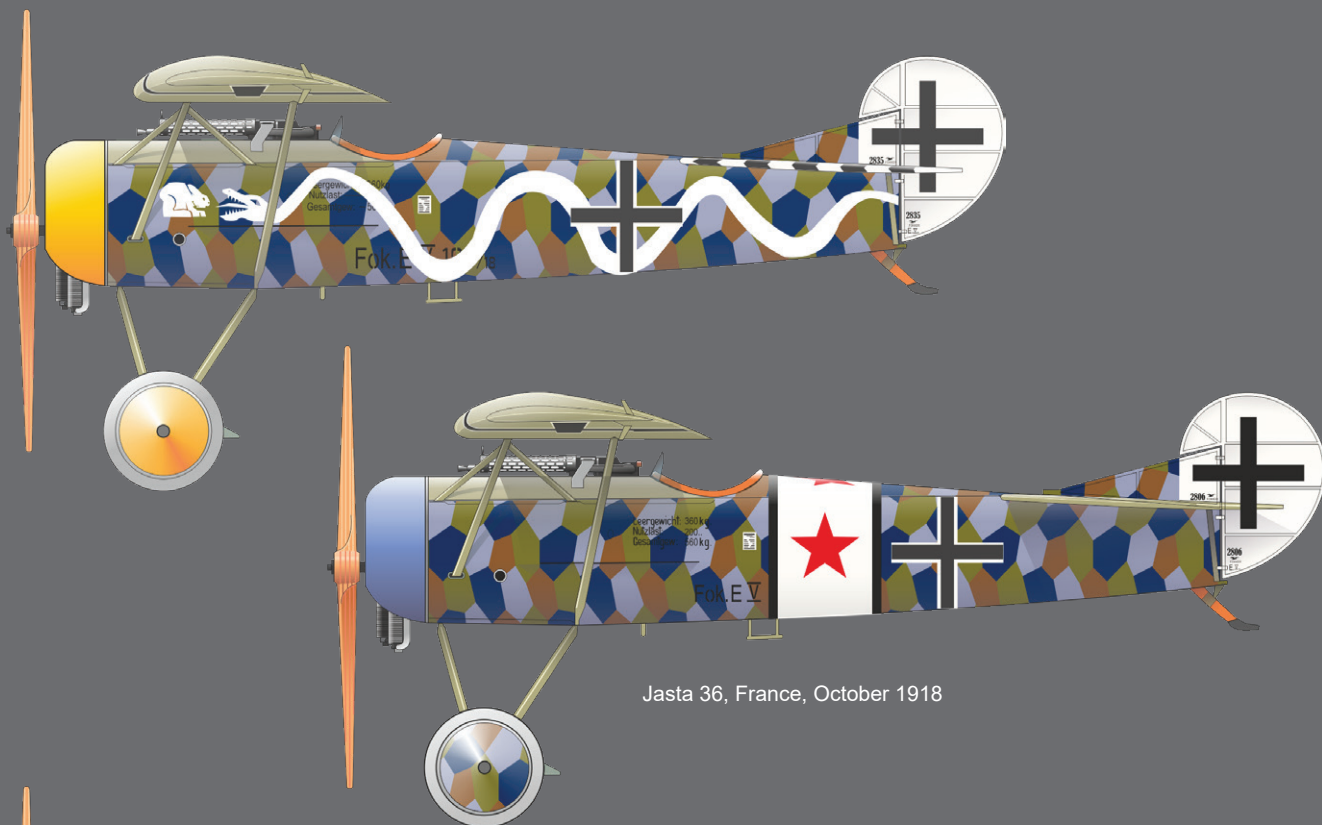

Jasta 36, France, October 1918

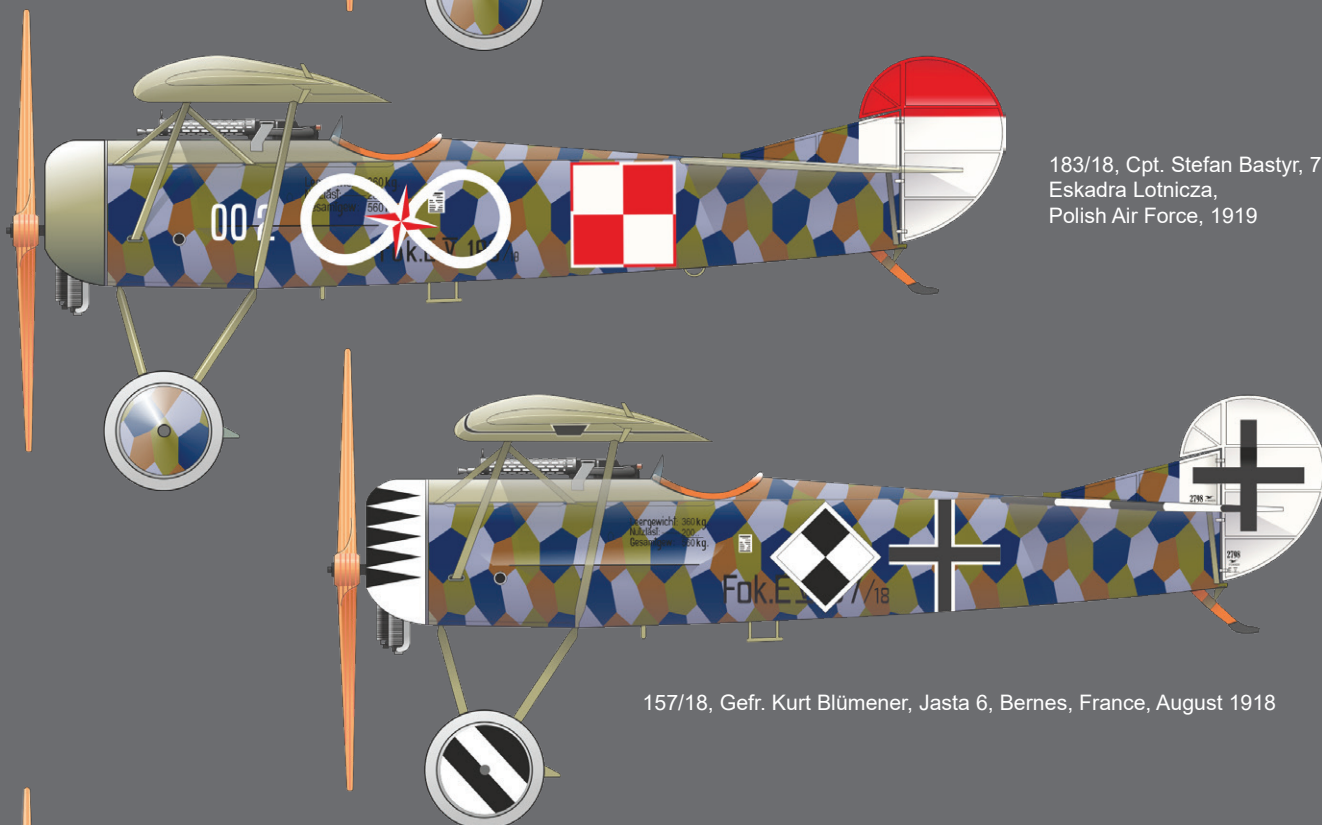

183/18, Cpt. Stefan Bastyr, 7. Eskadra Lotnicza, Polish Air Force, 1919

157/18, Gefr. Kurt Blümener, Jasta 6, Bernes, France, August 1918



Ltn. Theo Osterkamp, Marine Feld Jagdstaffel II, Belgium 1918



# Fokker D.VIII

## 1/48

Probably Jasta 8, Mercy-le-Haut, France, October 1918

Ownership of this aircraft remains a mystery. Some sources attach it to a Marine-Feldjagstaffel. Aircraft within these units, however, had their horizontal tail surfaces painted yellow, while this aircraft was adorned with stripes. This leads us to believe that the aircraft served with Jasta 8, who marked their Fokker D.VIIs in a similar fashion.

Jasta 8 was formed in September, 1916 and was based at airfield (Feldflieger Abtrilung) FFA6. It was progressively attached to several Jagdgruppe (JGr) when in March of 1918, Jasta 8 was permanently attached to JGr1, which was commanded by von Benthien. Among the units most prolific aces was W. Gotsch (20 kills, left Jasta 8 prior to the introduction of the Fokkers into inventory), W. Seitz (16 kills) and R. Francke (15 kills). Jasta 8 compiled a total of 91 victories during the course of the First World War, for the cost of five killed and eight wounded pilots.

[Product Page](#)  
Cat. No. 8085



built by Martin Jirkal

Camo A

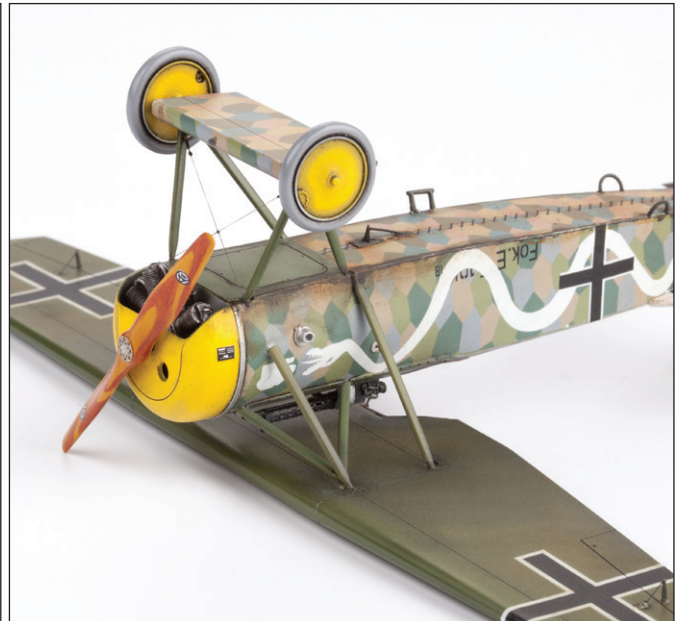



**183/18, Cpt. Stefan Bastyr, 7. Eskadra Lotnicza, Polish Air Force, 1919**

At the close of the First World War, the Polish Air Force obtained a number of Fokker E.V.s, and these went to Number 7 „Kosciuszkowske” Squadron, and were employed against Russian Bolsheviks. Aircraft 183/18 (number 002) was assigned to Cpt. Stefan Bastyr. For this native Teranovan, battle against Bolsheviks was not a new concept. Already as a reserve officer (Lt.i.Res.) of the Austro-Hungarian Air Force, he operated with Flik 10 on the eastern front. On the fourth of June, 1916 as an aerial observer, he shared in the downing of a Russian Farman.

# Fokker D.VIII

1/48



**Camo C**

**built by Pavel Zimandl**



[Product Page](#)

Cat. No. 8085





# RIDERS IN THE SKY 1944 1/72



## Liberator GR Mk.III and GR Mk.V in the RAF Coastal Command service

- Hasegawa plastic parts
- **Two unique plastic sprues** by Eduard (**NEW TOOL**)
- Eduard photo-etched details and painting mask
- Cartograf printed decals for 13 marking options of RAF Coastal Command Liberators GR Mk.III and GR Mk.V
- A2 size boxart **print** by Piotr Forkasiewicz
- **76 pages book** by Pavel Türk and Pavel Vančata related to the theme (in Czech language, English text available on Eduard website) with focus to No. 311 (Czechoslovak) Squadron RAF

1/72, Cat. No. 2121

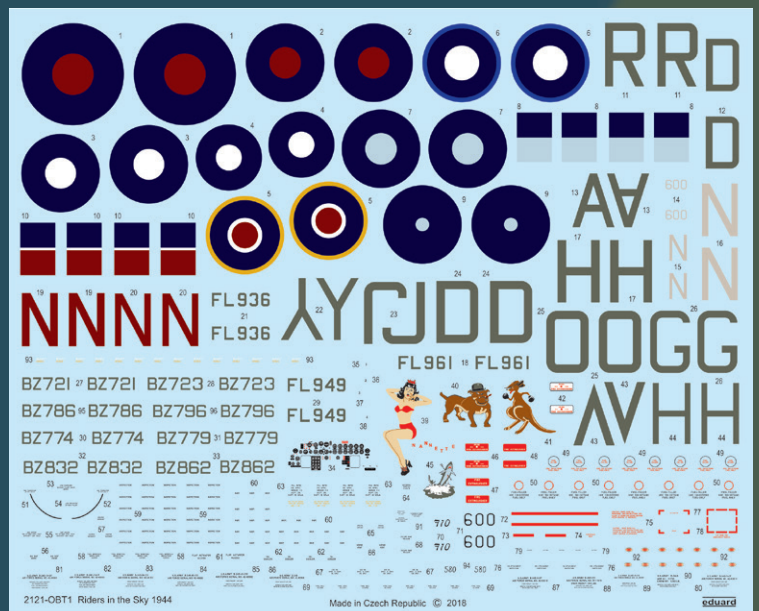

[Product Page](#)





Liberator GR Mk.V, BZ721, S/Ldr Terence Bulloch, No. 224 Squadron, St. Eval, Great Britain, July 1943



Liberator GR Mk.V, BZ723, S/Ldr Alois Šedivý, No. 311 Squadron, Tain, Great Britain, October 1944



Liberator GR Mk.V, BZ774, F/Sgt Otakar Žanta, No. 311 Squadron, Beaulieu, Great Britain, Autumn 1943



Liberator GR Mk.V, BZ779, F/Sgt Josef Kuhn, No. 311 Squadron, Beaulieu, Great Britain, October 1943



Liberator GR Mk.V, BZ786, P/O Jan Irving, No. 311 Squadron, Beaulieu, Great Britain, Autumn 1943



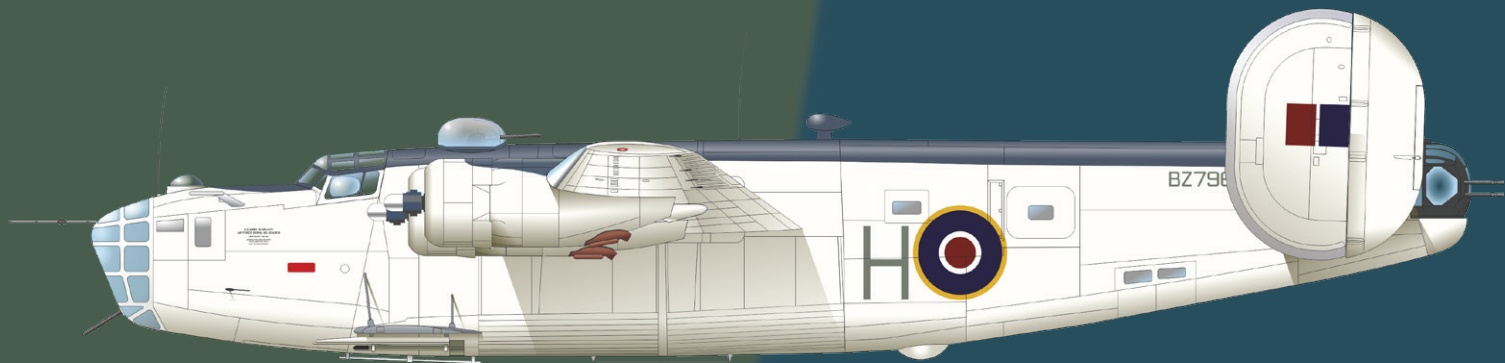

Liberator GR Mk.V, BZ796, P/O Oldřich Doležal, No. 311 Squadron, Beaulieu, Great Britain, December 1943



Liberator GR Mk.V, FL961, F/O Jan Vella, No. 311 Squadron, Predanack, Great Britain, June 1944



Liberator GR Mk.V, FL949, F/O Josef Pavelka, No. 311 Squadron, Tain, Great Britain, October 1944

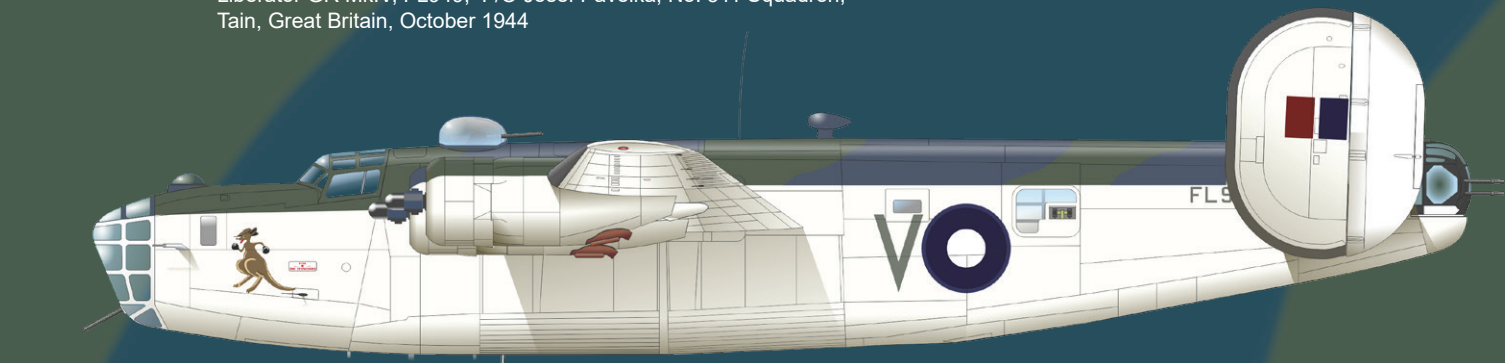

Liberator GR Mk.III, FL936, P/O Ben Hall, No. 160 Squadron, Sigiriya, Ceylon, Autumn 1943

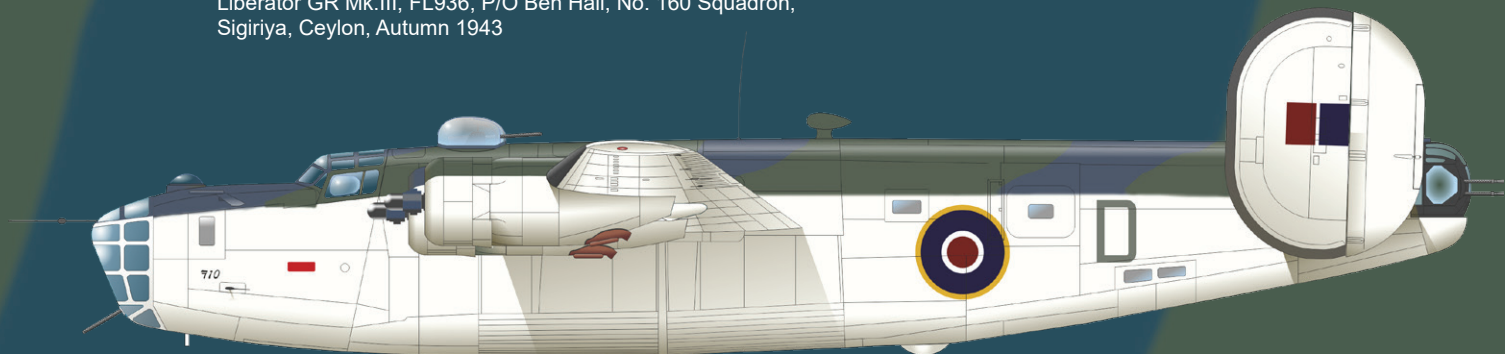

Liberator GR Mk.V, BZ832, F/O Lloyd A. Trigg, No. 200 Squadron, Yundum, Gambia, August 1943





Liberator GR Mk.V, BZ862, F/Lt John A. Muir, No. 354 Squadron, Minneriya, Ceylon, July 1945



Liberator GR Mk.V, BZ755, F/O A. Cirko, No. 10 (BR) Squadron RCAF, Gander, Canada, Autumn 1943



Liberator GR Mk.V, BZ755, No. 10 (BR) Squadron RCAF, Gander, Canada, Summer 1945

## Recommended for kit 2121:

- 73627 Liberator GR Mk.V upgrade set 1/72 (PE-Set)
- 672170 B-24 wheels 1/72 (Brassin)
- 672171 B-24 engines 1/72 (Brassin)
- 672172 British 250lb depth charges 1/72 (Brassin)
- 672177 B-24 bomb bay rocket projector 1/72 (Brassin) (2018/04)
- 672178 B-24 turbochargers 1/72 (Brassin) (2018/04)
- 672183 B-24 bomb bay doors 1/72 (Brassin) (2018/04)

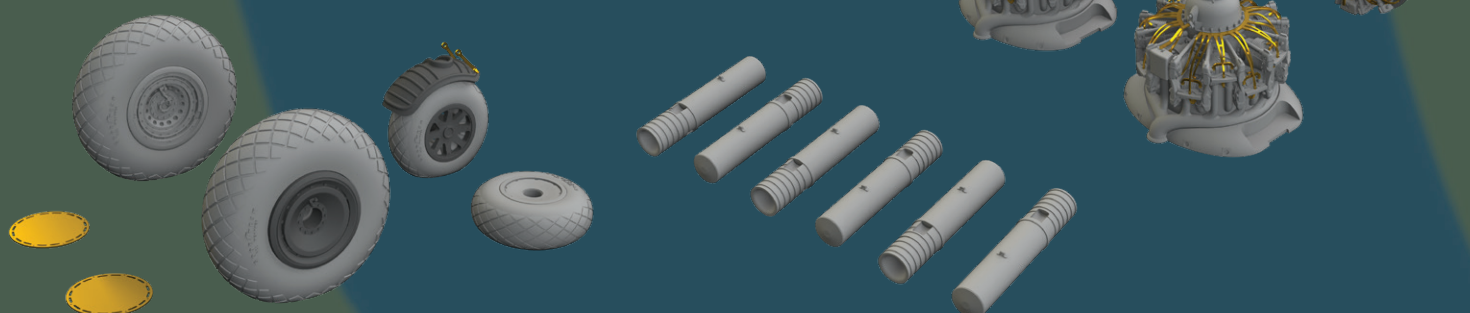



# RIDERS IN THE SKY 1944 1/72



Camo B

built by Tomáš Török

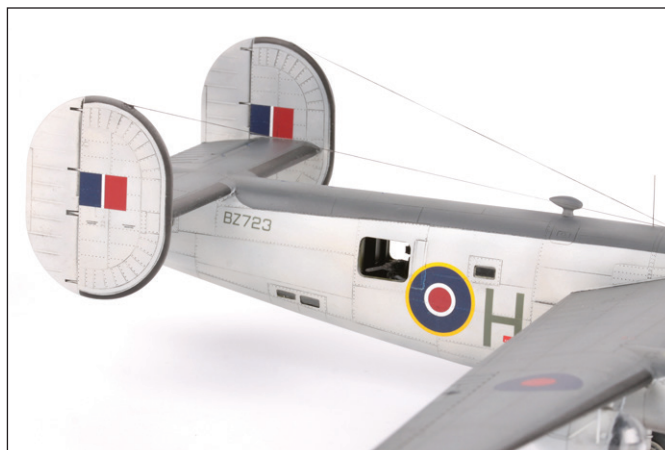

Liberator GR Mk.V, BZ723, S/Ldr Alois Šedivý, No. 311 Squadron, Tain, Great Britain, October 1944



[Product Page](#)  
Cat. No. 2121







Emblem of the Czechoslovak No. 311 Squadron RAF consisted of Hussite weapons and motto. The Hussite war history in 15th Century should be known. But there is less known, that in this Czechoslovak squadron some centuries later served not only Czechs and Slovaks, but Bohemian Germans and Jews as well.

1

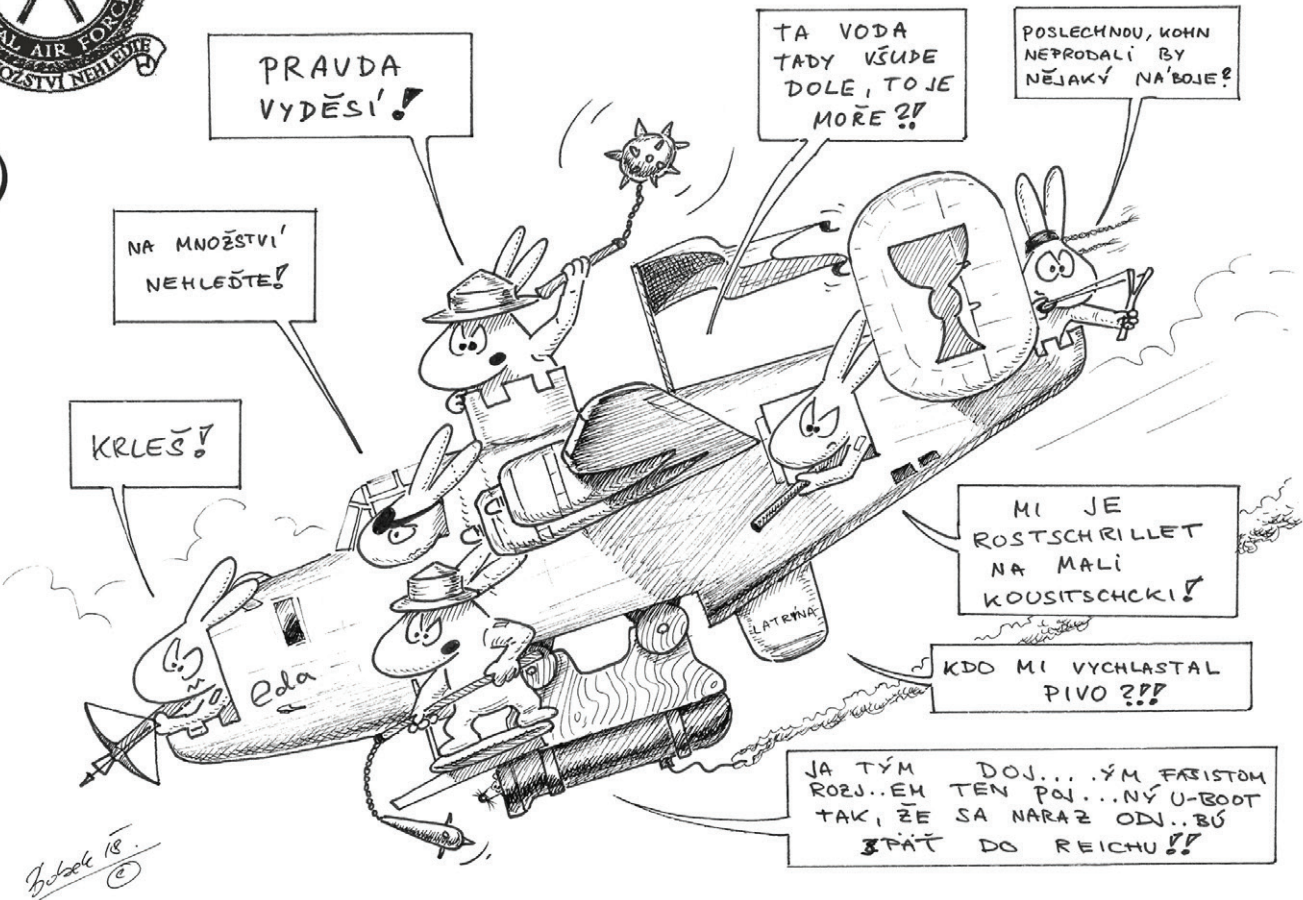

eduard

2

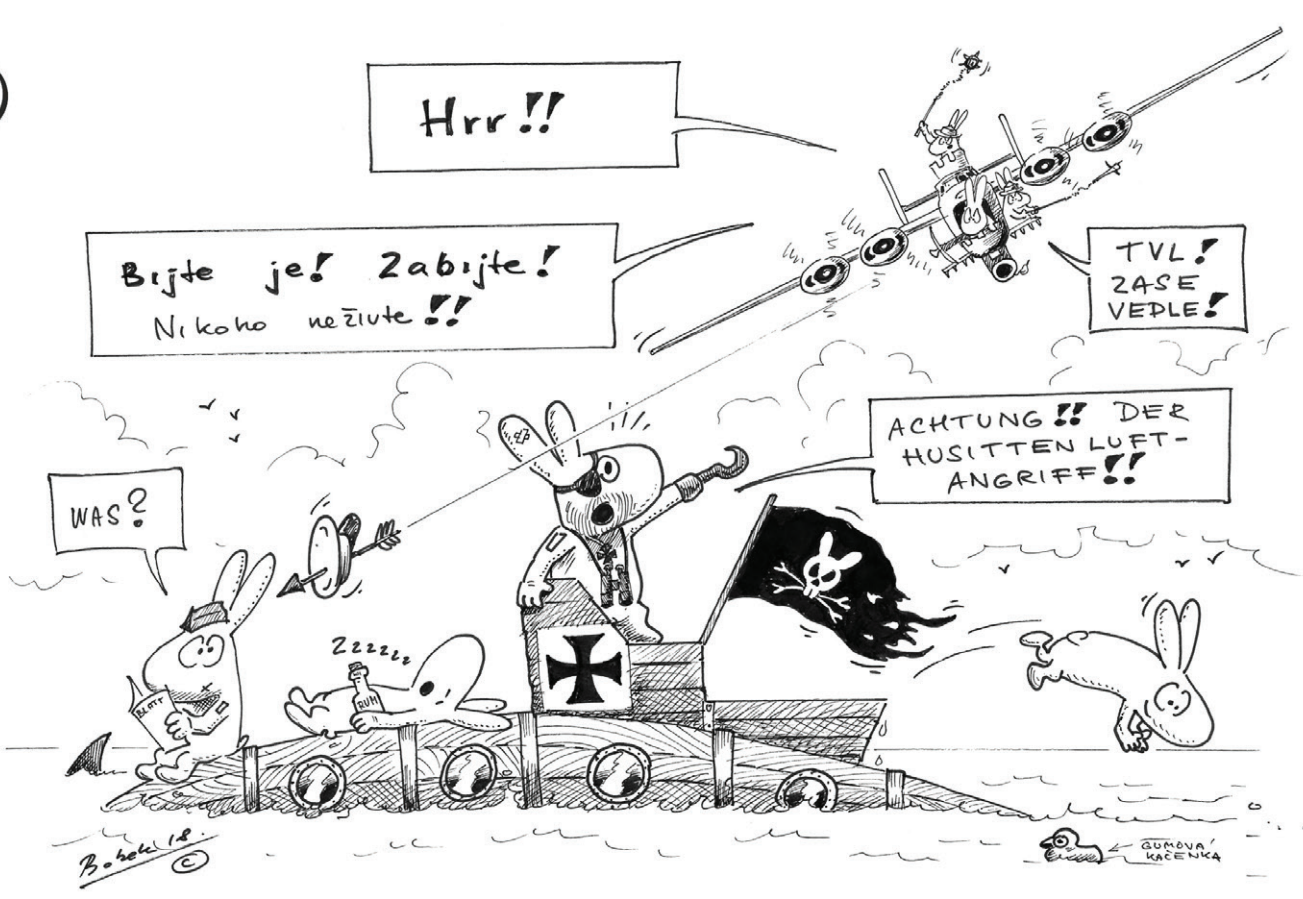



## F/O Lloyd Allan Trigg VC, DFC

5 May 1914 / 11 August 1943

Lloyd Allan Trigg was born in Houhora, Northland, New Zealand. In 1927 he started to attend Whangarei High School. Soon after that, his father died. Three years later, his mother died, too. These tragic moments undoubtedly influenced his approach to life. He first wanted to become a teacher, he even started to attend preparation classes for Auckland University College, but the ongoing economic crisis made him decide otherwise. In 1932, after he graduated from Whangarei High School, he started to work on sheep farms. Later he worked as a sales representative of company supplying accessories for farmers. In 1938, he got married and settled in Victoria Valley.

The first year of WWII he served at North Auckland Rifles Regiment, the part of Territorial Force (he was the member of the regiment since 1932). He could have asked for exemption from military service, instead of that, on 15 June 1941, he filed an application to Royal New Zealand Air Force. He went through a training in Canada. When he was about to leave his wife and his two small sons, he told her: "Don't worry, I am not going there to collect medals". On 16 January 1942, after he completed the training, he got pilot badge and a rank of Pilot Officer. He then continued his training, that time, he was trained for Lockheed Hudson aircraft. On 28 October 1942, after he completed the Lockheed Hudson training, he boarded a ship headed for the British Isles. In December 1942, he was sent to Western Africa where he joined No. 200 Squadron equipped with Hudsons for navy patrol flights. He was a dedicated pilot, he would fly dis-

regarding any unfavorable conditions. In March, during the escort flights protecting the convoys, he struck two times at the submarines, this earned him proposal for a Distinguished Flying Cross. On 18 June 1943, the awards were announced in the London Gazette. Unfortunately, F/O Trigg, had never got to know about this (the message reached Africa after the RAF lost the BZ832 Liberator and its crew had died). He flew in total 46 operational flights on Hudsons.



In May 1943, three crews (including the F/O Trigg's crew) were sent to No. 111 (C) OTU to Bahamas to be retrained for Liberators. The No. 200 Squadron was supposed to change all their aircraft for Liberators.

F/O Lloyd Allan Trigg died on 11 August 1943 during the first operational flight with Liberator BZ832 "D". His Liberator was shot down during the attack on U 468 submarine, but the submarine was sunk. For his deed of valor, F/O Trigg, was awarded Victoria Cross posthumously.

## Victoria Cross

Victoria Cross is the highest military award of the UK honors system awarded to armed forces of the British Commonwealth (formerly it applied to the territory of British Empire) for deeds of valor in the face of the enemy. The award could be awarded to any military rank and to civilians under military command. The VC was introduced on 29 January 1856 by Queen Victoria to honor acts of valor of soldiers fighting in Crimean War. The VC thus applied retrospectively to all acts of valor since 1854. It was first awarded on 26 June 1857. In association with the awards, the survivors of the bearer of the VC get yearly pension. A total of 1,358 Victoria Crosses have been awarded since 1856 to 1,355 individual bearers (only three people have been awarded this award two times - VC & Bar - the bar represented the second award). The last VC was awarded in 2015 (for military actions of 22 August 2013). Since the WWII, the VC has only been awarded fifteen times.

Till nowadays there have been 51 airmen in total who were decorated the VC. Out of that 32 for valor shown during WWII. Only three of these airmen were of RAF Coastal Command. The first one was F/O Kenneth Campbell of No. 22 RAF Squadron (Beaufort Mk.I N1016 "OA o X"), who got the awards for an attack of 6 April 1941 aiming at German battleship Gneisenau anchoring in the port of Brest. The second awarded pilot was F/O L. A. Trigg. Third man was the member of No. 162 RCAF Squadron, F/Lt David Ernest Hornell, for his attack conducted with Canso 9754 "P". During the attack, a U 1225 submarine was sunk, and it took place on 24 June 1944. These three VCs were awarded posthumously. The last airman awarded the VC was F/Lt John Alexander Cruickshank of No. 210 Squadron, who managed to sink U 361 submarine with his Catalina JV928 "Y" on 17 July 1944. After they landed, the medical staff found in total 72 shots in his body, but they still managed to save his life.

With respect to the above mentioned figures it is clear that this award is very appreciated not only among its bearers, but also among the collectors. The Victoria Cross awarded to F/O L. A. Trigg, for instance, was sold at an auction organized by Spink Auction House on 6 May 1998, for a record £120,000. The new owner of Trigg's VC was

Michael Ashcroft Trust, a holding administering the Victoria Cross collection of Lord Ashcroft. In 1998, when the Triggs VC was sold at an auction, the VC was not sold by Trigg's family, they had sold it much earlier. The money they got was enough for them to buy them a house.

Victoria Cross had allegedly (except for a few pieces) been made of Russian cannons captured in Crimean War. The metal part of the VC weighs 27g and has a height of 41mm and a width of 36mm.





The first Liberators GR Mk.V (BZ829 "A", BZ830 "B", BZ831 "C", BZ832 "D", BZ823 "E", BZ824 "F", BZ825, BZ826 a BZ827) arrived at No. 200 Squadron base in Yundum, Gambia, at the end of July 1943. L. A. Trigg, flew one of the aircraft from Dorval (nowadays Montreal Airport, Canada) through Prestwick to Yundun base.

On 11 August 1943, the No. 200 Squadron conducted the first operational flight with Liberators. On that day, shortly after dawn, at 07:29, two aircraft, BZ830 (W/O "Rikki" Johnson) and BZ832 (F/O L. A. Trigg), took off the detached base in Rufisque near Dakar, to conduct an anti-submarine patrol scheduled for an area about 724km south-west of Bathurst. The planes were equipped with American depth charges. During the flight, both aircraft got a command to attack the submarine, which had been attacked by Catalina (W/Cdr D. W. Baird, F/O N. A. Ward) of No. 490 Squadron. The search for submarine was unsuccessful and the Liberator BZ830 got back to the base. The second aircraft, though, disappeared without a trace. The search had gone underway. The next day in the morning, Sunderland "H" of No. 204 Squadron found a dinghy full of castaways. The Sunderland crew expected them to be the crew of the Liberator and dropped them supplies. One day after that, on 13 August 1943, the mystery of the missing Liberator BZ832 started to untangle. On that day, the HMS Clarkia Corvette, given the coordinates from Sunderland, picked the castaways spotted in the dinghy. Shortly after, though, the corvette crew found out that the castaways had not been the men from Liberator crew, but German sailors. Their story revealed the fate of Trigg's crew.

On 11 August 1943, at 09:45, Trigg's crew spotted an emerged submarine (about five kilometers away from them, at 12° 20' N and 20° 07' W). F/O L. A. Trigg, immediately started the attack. The crew of German U 468 (type VIIC) fired back at Liberator, too. The German sailors aimed well, they hit the Liberator several times and the plane went on fire. Cap-

tain Trigg continued the attack despite the fire and dropped six depth charges at the submarine from an altitude of about 15m; two of them exploded in a distance shorter than two meters away from the submarine. After the overflight, the Liberator continued its descending flight and couple of hundred meters away from the submarine the plane hit the surface of water and exploded. German soldiers did not have time to celebrate their victory either. The explosion of the depth charges damaged the submarine badly. There was a major leak of poisonous chlorine from the batteries and the captain ordered the sailors to leave the vessel. Only twenty sailors managed to escape, though. Ten minutes after the beginning of the Liberator attack, the U 468 vanished in the depths of the sea with the rest of the crew.

The blood of the injured sailors attracted the sharks and the tragedy continued. One hour later, one of the sailors discovered the dinghy coming from the crashed Liberator and the remaining members of German Kriegsmarine got into it. One of the survivors was the commander of the submarine, Oberleutnant zur See Klemens Schamong, his first officer, Alfons Heimannsberg, and the leading engineer Emil Giesbert.

Their testimony on the valor of Allan Trigg's Liberator crew lead to F/O Lloyd Allan Trigg's award by the highest award of the UK honor system, Victoria Cross. On 2 November 1943, The London Gazette paper published the message that the King awarded Victoria Cross to F/O L. A. Trigg for exceptional deed of valor. All names of the members of his crew - the co-pilot, P/O G. N. Goodwin, navigator, F/O Ivan Marinovich (he also flew in Trigg's original crew on Hudsons), the second navigator, F/O J. J. S. Townshend, radio operator/gunner, F/Sgt Arthur G. Bennett (also flew in Trigg's original crew on Hudsons), radio operator/gunner, F/Sgt Terry J. Soper, radio operator/gunner, F/Sgt Lawrence J. Frost, and radio operator/gunner, F/Sgt A. R. Bonnick - are inscribed on the Malta Memorial. The Germans lost 42 sailors.

Liberator GR Mk.V, BZ832, F/O Lloyd A. Trigg, No. 200 Squadron, Yundum, Gambia, August 1943



Liberator GR Mk.V BZ826, No. 200 Squadron, Yundum base, Gambia, July 1943. The aircraft had the ASG-3 centimetric radar installed.







Liberator GR Mk.V BZ826 "L", No. 200 Squadron, St. Thomas Mount base, Madras, India 1944. In February 1944, the squadron was ordered to move from Africa to India. Majority of its aircraft reached the Indian base on the break of March and April. The plane already bears the ACSEA markings. Notice the Boulton-Paul Type E tail turret with black framing.

Liberator GR Mk.V, BZ832, F/O Lloyd A. Trigg, No. 200 Squadron, Yundum, Gambia, August 1943

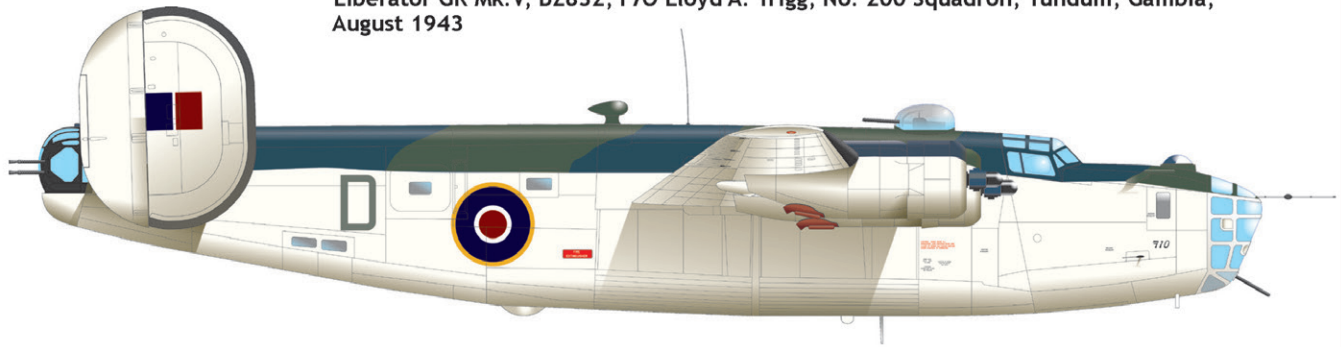

W/Cdr Ingle welcomes the GR Mk.V BZ829 crew, NO. 200 Squadron, Yundum base, July 1943.







#BFC023

1/48

# MERSU

**ONLY FOR BFC MEMBERS.**

[Product Page](#)

1/48, Cat. No. BFC023

- Complete kit MERSU (ProfiPACK Cat. No. 11114, Bf 109G-2 and G-6 Dual Combo)
- Unique decal sheet for MT-422 aircraft, with shark mouth.
- One pair of Brassin undercarriage wheels

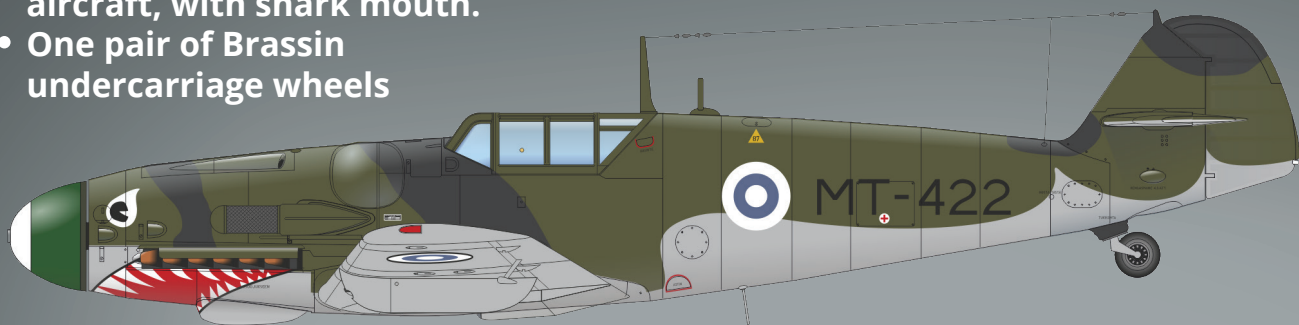
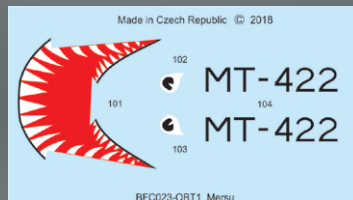

Bf 109G-6, MT-422, HLeLv 31, Utti, Finsko, Únor 1948





# Avia Bk.534 Graf Zeppelin

1/72, Cat. No. 7445



c/n 594, Erprobungsstelle Travemünde, Travemünde, Germany, 1940/ 1941

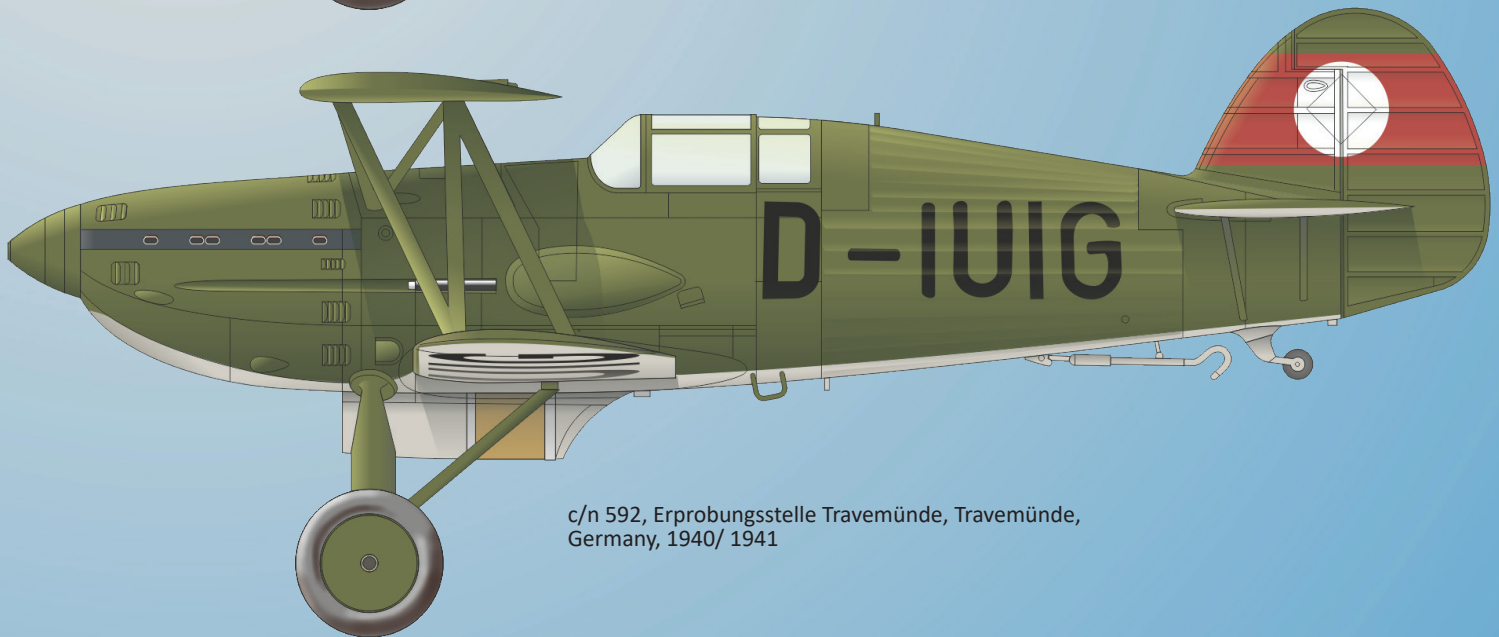

c/n 592, Erprobungsstelle Travemünde, Travemünde, Germany, 1940/ 1941

- 2 markings
- decals Eduard

[Product Page](#)

**RECOMMENDED:**

72602 Avia B.534 wires & stretchers (PE-Set)

D-IUIG D-IUIG  
D-IWNF D-IWNF  
D-IWNF D-IWNF D-IUIG D-IUIG

7445-OBT1 Avia Bk.534 Graf Zeppelin

Made in Czech Republic

Eduard M.A. © 2018



03/2018

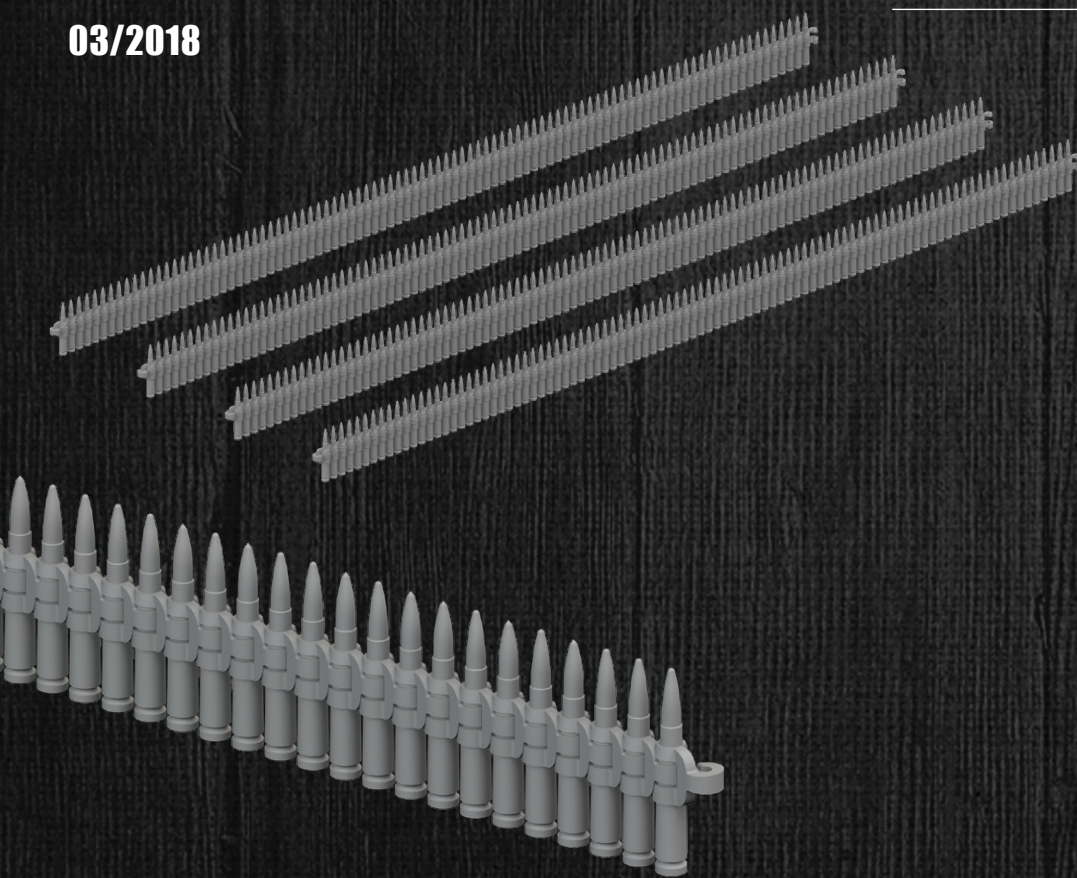

Brassin set - 12,7mm ammunition belts in 1/32 scale. Set consists of four belts.

Set contains:

- resin: 4 parts,
- decals: no,
- photo-etched details: no,
- painting mask: no.

[Product Page](#)

648384

## AGM-154C Block II

1/48

Brassin set - US guided missile AGM-154C Block II in 1/48 scale. Used on F/A-18 from 2006. Set consists of two missiles. Can be assembled either in deployed or stowed positions.

Set contains:

- resin: 24 parts,
- decals: yes,
- photo-etched details: no,
- painting mask: no.

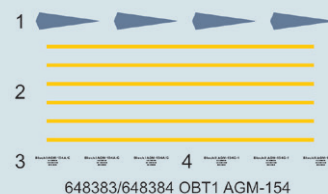
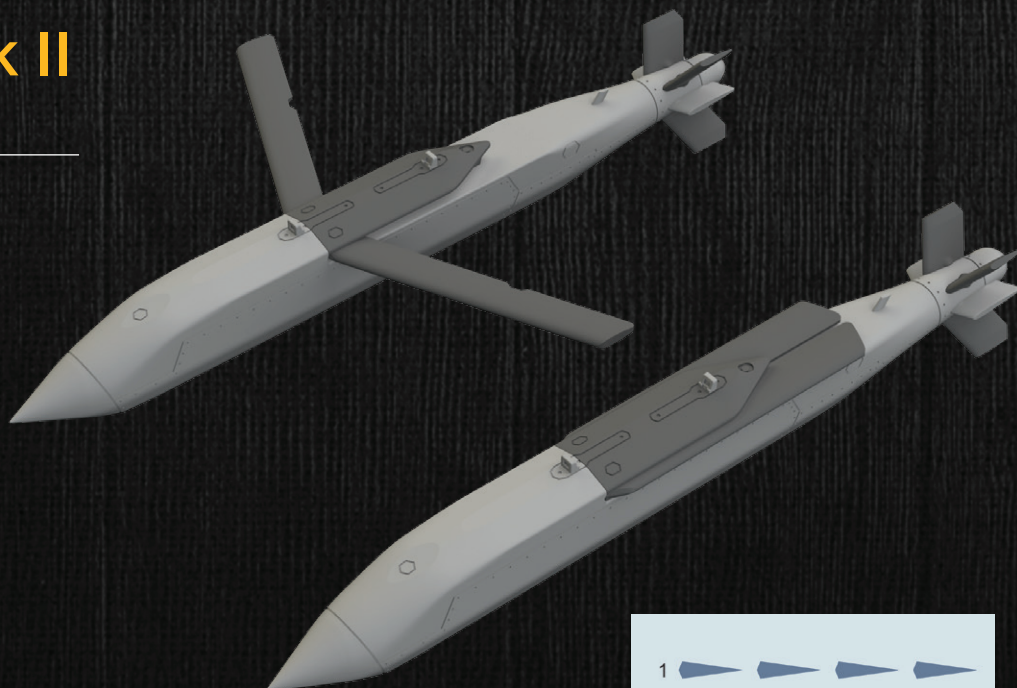
[Product Page](#)



648385

# GBU-38 Non-Thermally Protected

1/48



Brassin set - 4 pieces of US guided aerial bomb GBU-38 JDAM in 1/72 scale.

Set contains:

- resin: 36 parts,
- decals: yes,
- photo-etched details: yes,
- painting mask: yes.

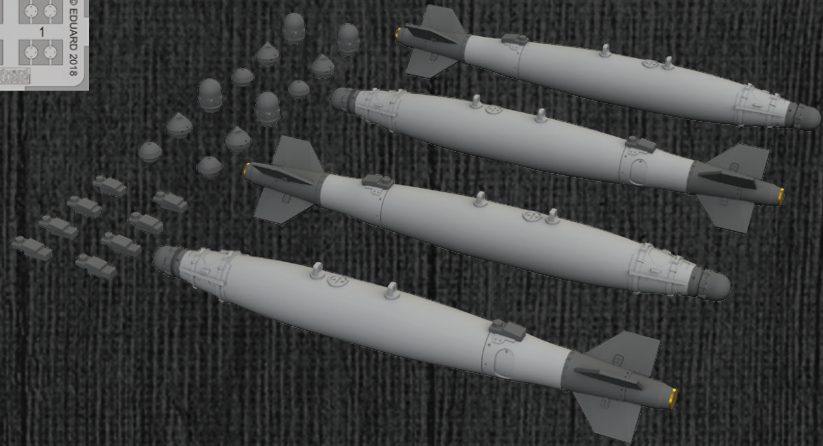
[Product Page](#)

648387

# F-8E Crusader wheels

1/48 Hasegawa

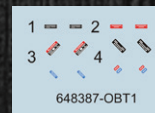
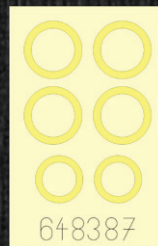

Brassin set - undercarriage wheels for F-8E Crusader in 1/48 scale. Easy to build, replaces plastic parts. Recommended kit: Hasegawa

Set contains:

- resin: 5 parts,
- decals: yes,
- photo-etched details: no,
- painting mask: yes.

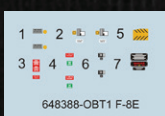
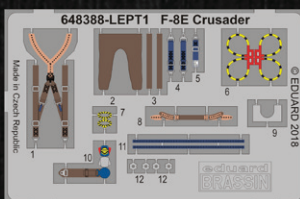
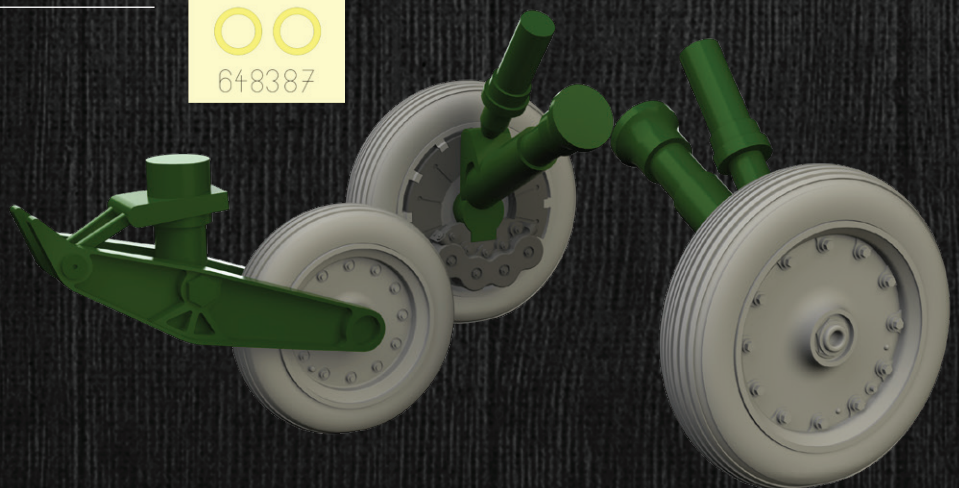
[Product Page](#)

# 648388 F-8E Crusader ejection seat

1/48 Hasegawa

Brassin set - ejection seat for F-8E Crusader in 1/48 scale. Easy to build, replaces plastic parts. Recommended kit: Hasegawa

Set contains:

- resin: 3 parts,
- decals: no,
- photo-etched details: yes, pre-painted,
- painting mask: no.

[Product Page](#)





648390  
**Fw 190A-5 cockpit**  
 1/48 Eduard

Brassin set - cockpit for Fw 190A-5 in 1/48 scale. Easy to build, replaces plastic parts. Recommended kit: Eduard

- Set contains:
- resin: 21 parts,
  - decals: yes,
  - photo-etched details: yes, pre-painted,
  - painting mask: no.

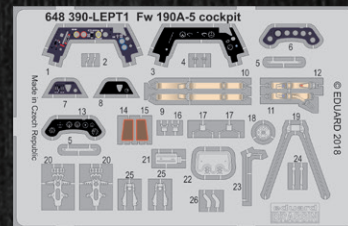
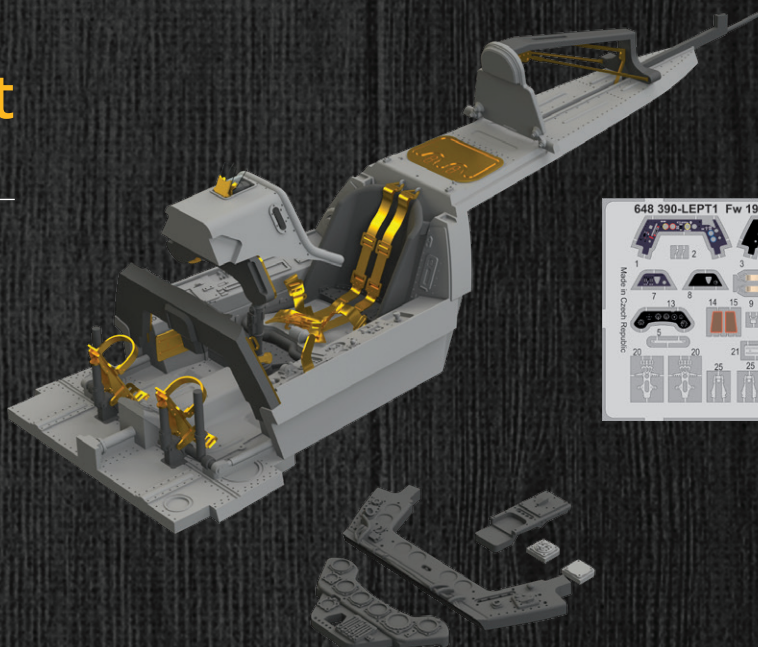
[Product Page](#)



648391  
**Fw 190A-5 engine**  
 1/48 Eduard

Brassin set - engine for Fw 190A-5 in 1/48 scale. Recommended kit: Eduard

- Set contains:
- resin: 22 parts,
  - decals: no,
  - photo-etched details: yes,
  - painting mask: no.

[Product Page](#)

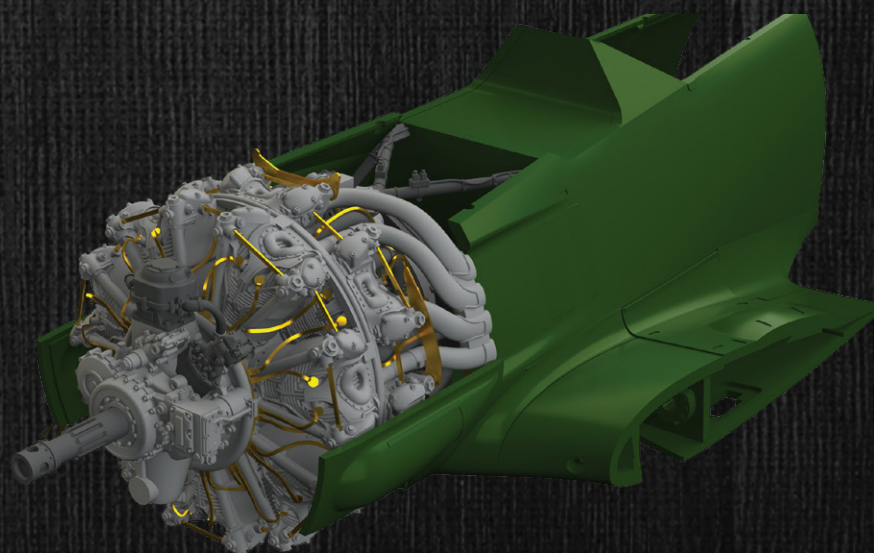

648392  
**Fw 190A-5 fuselage guns**  
 1/48 Eduard

Brassin set - fuselage guns for Fw 190A-5 in 1/48 scale. Two versions of upper fuselage cover. Recommended kit: Eduard

- Set contains:
- resin: 18 parts,
  - decals: no,
  - photo-etched details: yes,
  - painting mask: no.

[Product Page](#)

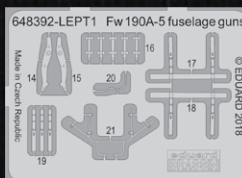
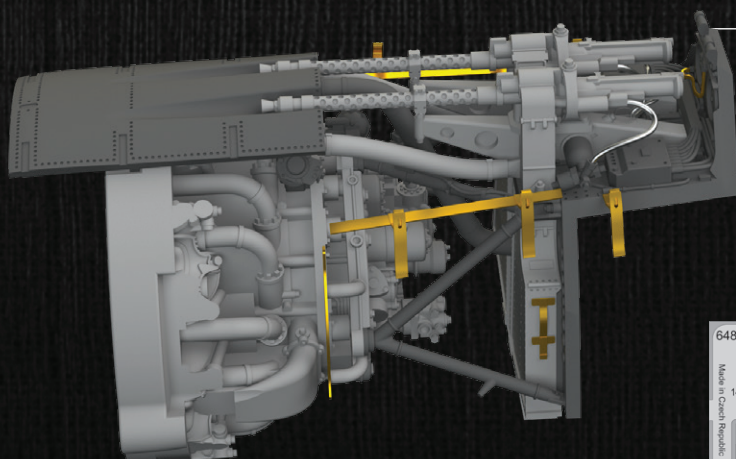



648393

**British Rocket Projectiles RP-3 60lb F.**

1/48

Brassin set - British WWII rocket projectiles in 1/48 scale. Set contains eight rockets.

Set contains:

- resin: 8 parts,
- decals: yes,
- photo-etched details: no,
- painting mask: no.

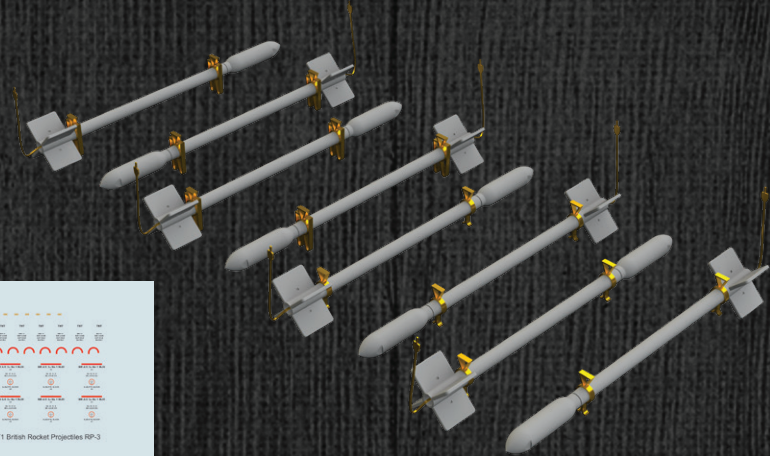
[Product Page](#)

648394

**British Rocket Projectiles RP-3 60lb S.A.P.**

1/48

Brassin set - British WWII rocket projectiles in 1/48 scale. Set contains eight rockets.

Set contains:

- resin: 8 parts,
- decals: yes,
- photo-etched details: no,
- painting mask: no.

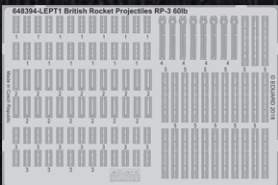
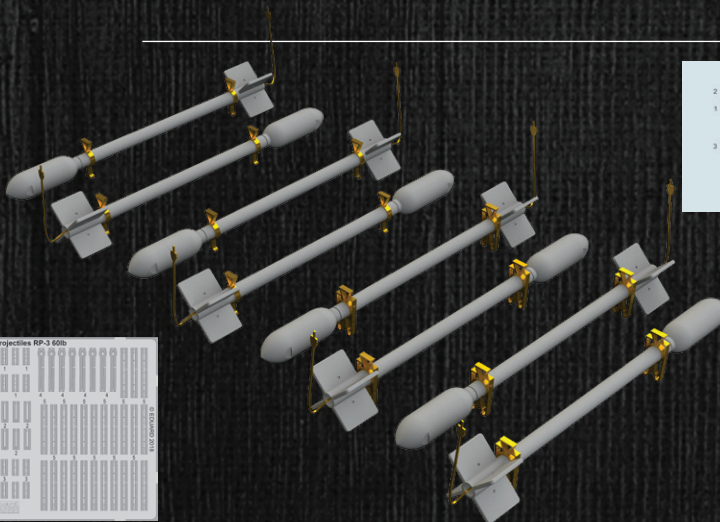
[Product Page](#)

672169

**AN/ALQ-184 (short) ECM pod**

1/72

Brassin set - ECM pod AN/ALQ-184 (short) in 1/72 scale. Used on A-10, F-16 aircraft.

Set contains:

- resin: 1 part,
- decals: yes,
- photo-etched details: no,
- painting mask: no.

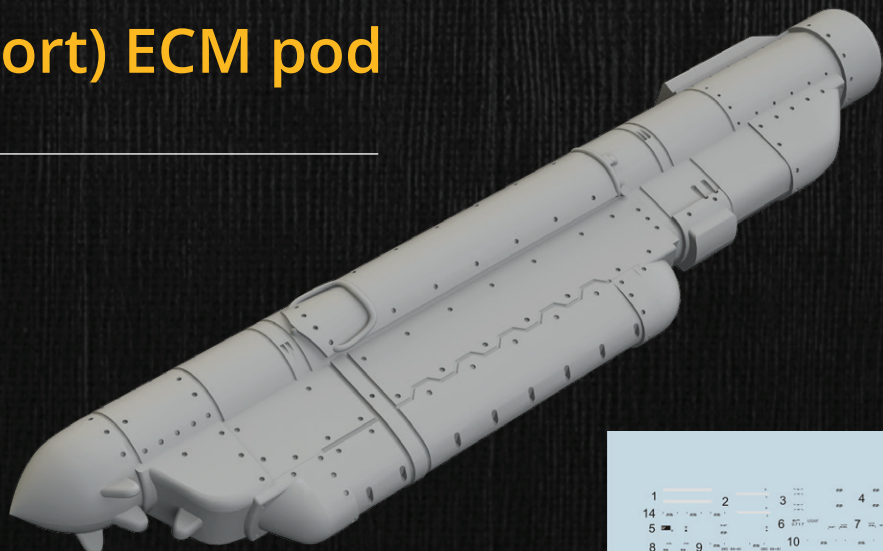
[Product Page](#)



**672170**  
**B-24 wheels**  
 1/72 Eduard/Hasegawa

Brassin set - undercarriage wheels for B-24 Liberator bomber in 1/72 scale.  
 Recommended kit: Eduard / Hasegawa

- Set contains:
- resin: 10 parts,
  - decals: no,
  - photo-etched details: yes,
  - painting mask: yes.

[Product Page](#)

**RIDERS IN THE SKY**  
 1944 1/72

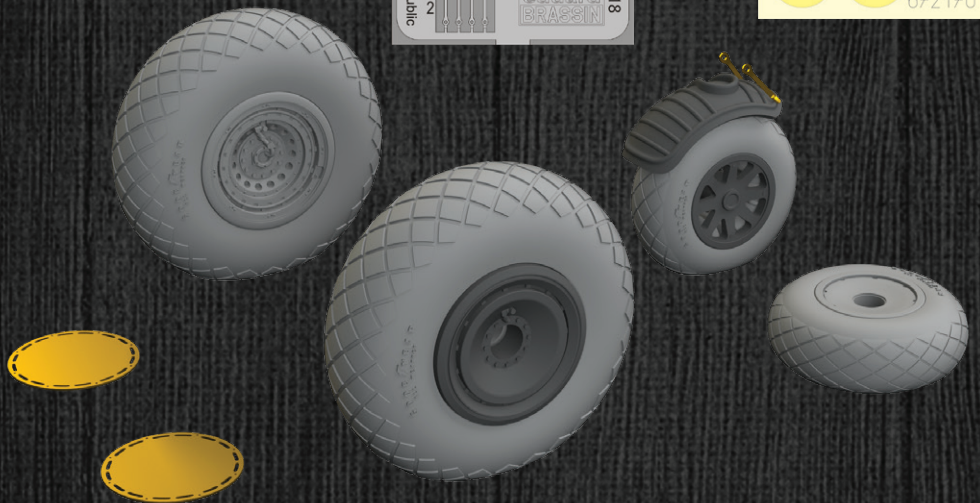
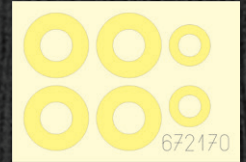
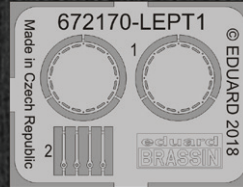

**672171**  
**B-24 engines**  
 1/72 Eduard/Hasegawa

Brassin set - engines for B-24 Liberator bomber in 1/72 scale.  
 Recommended kit: Eduard / Hasegawa

- Set contains:
- resin: 8 parts,
  - decals: no,
  - photo-etched details: yes,
  - painting mask: no.

[Product Page](#)



**RIDERS IN THE SKY**  
 1944 1/72



**672172**  
**British 250lb depth charges**  
 1/72

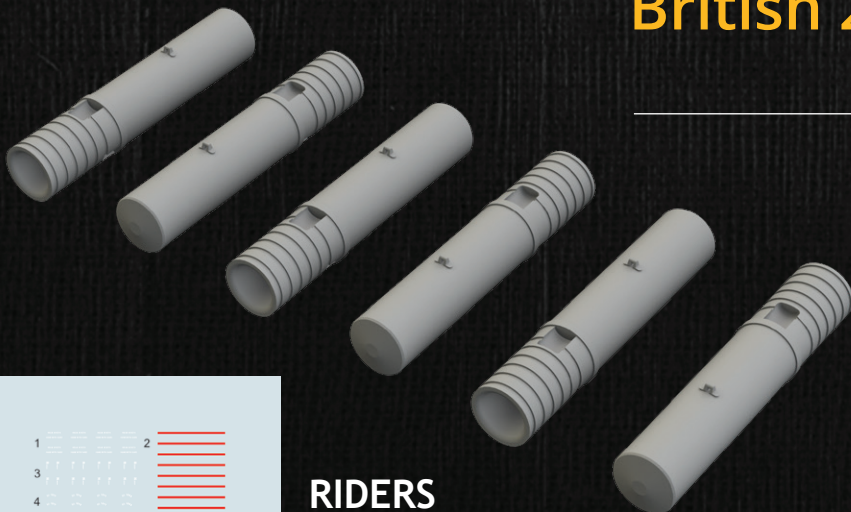

Brassin set - British 250lb depth charges in 1/72 scale. Set consists of six depth charges. Recommended for 1/72 Liberator kit.

- Set contains:
- resin: 6 parts,
  - decals: yes,
  - photo-etched details: no,
  - painting mask: no.

[Product Page](#)

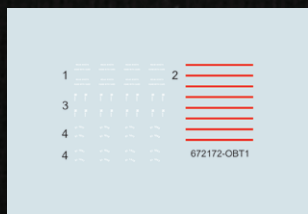

**RIDERS IN THE SKY**  
 1944 1/72



SIN63212  
**F4U-1D**

1/32 Tamiya

Collection of 4 Brassin sets for F4U-1D  
 in 1/32 scale by Tamiya.

- cockpit,
- engine,
- wheels,
- propeller.

All sets included in this BIG SIN are available separately,  
 but with every BIG SIN set you save up to 30%.



[Product Page](#)

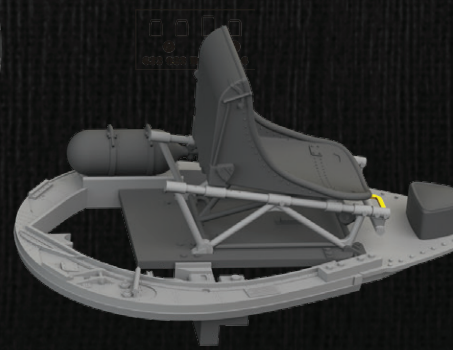
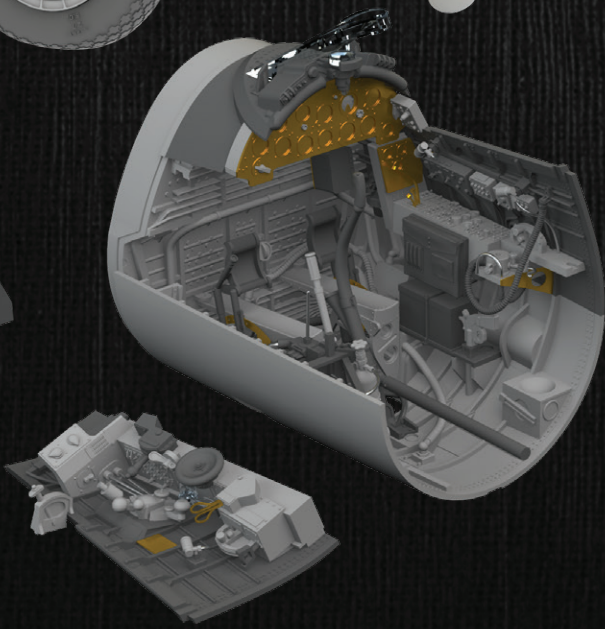
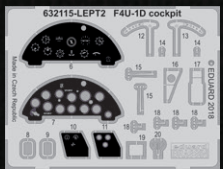
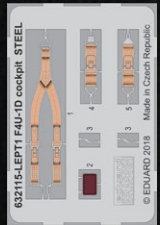
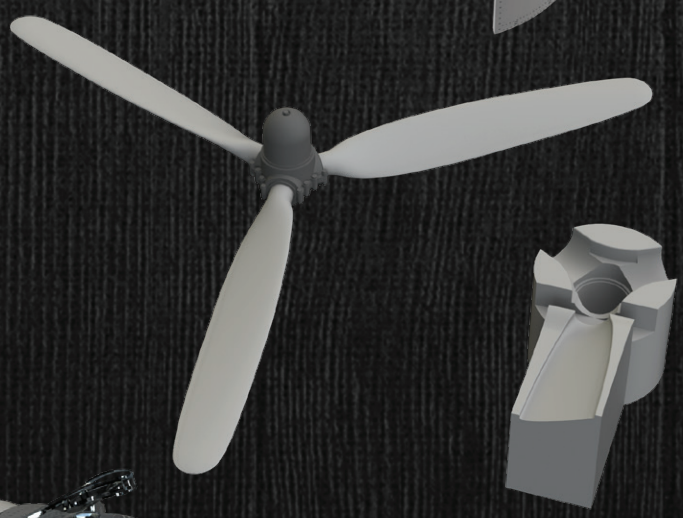
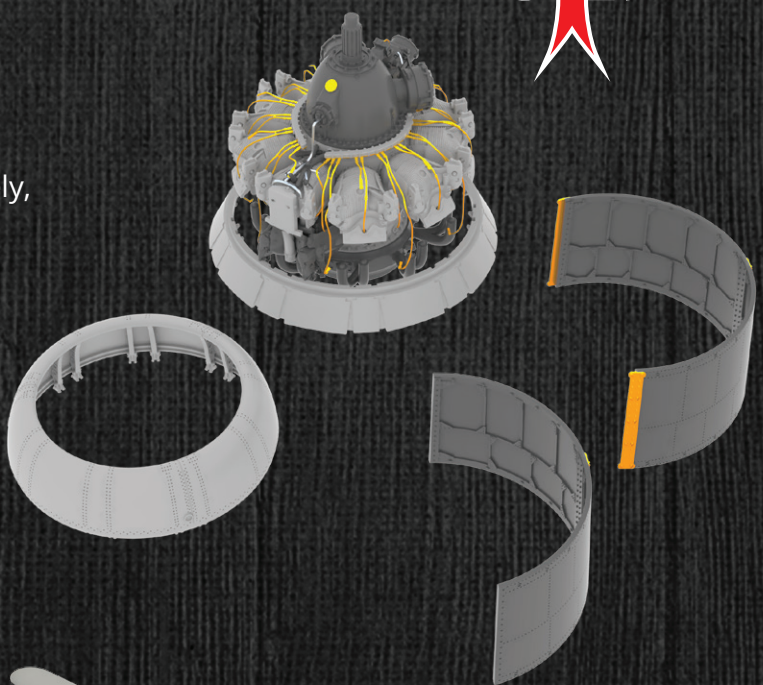
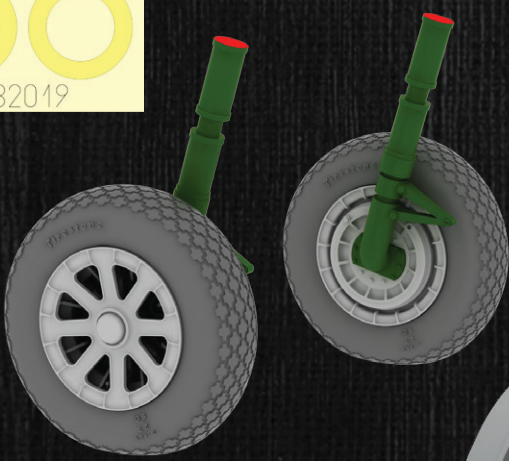
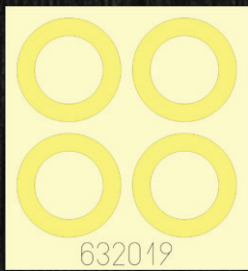
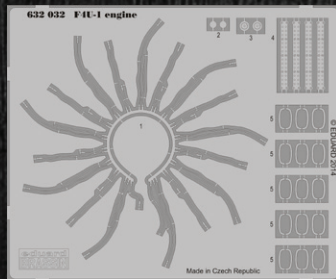



SIN64842

# Bf 109G-4 essential

1/48 Eduard

Collection of 4 Brassin sets for Bf 109G-4 in 1/48 scale by Eduard.

- cockpit,
- control surfaces,
- wheels,
- Pitot tubes.

All sets included in this BIG SIN are available separately, but with every BIG SIN set you save up to 30%.



Product Page 

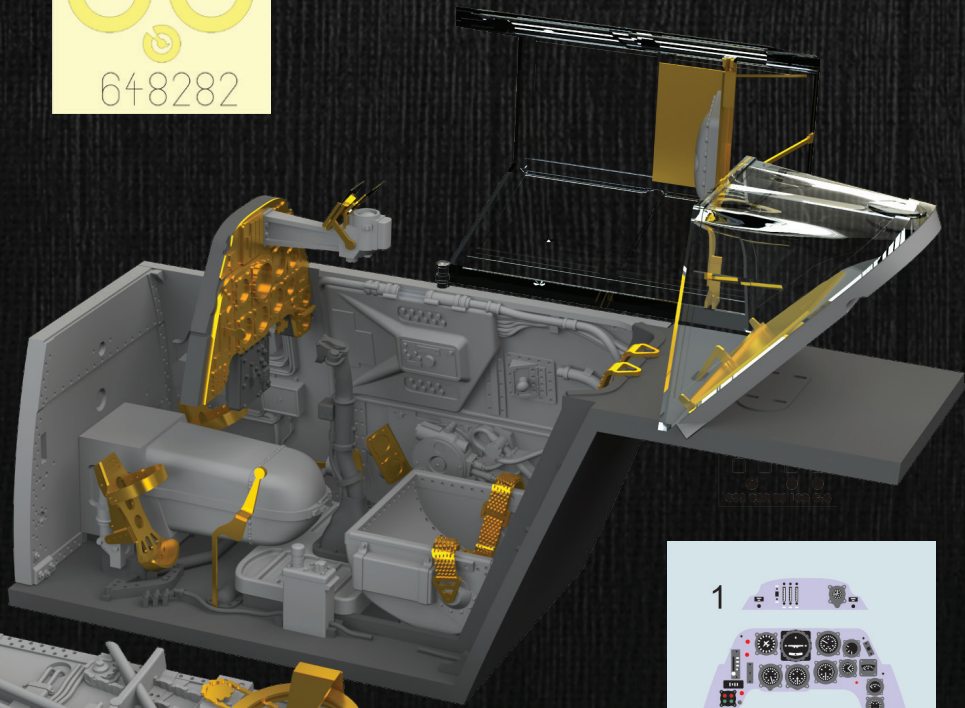
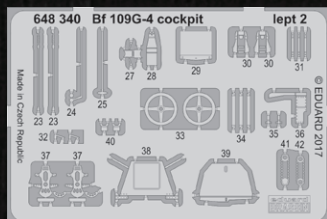
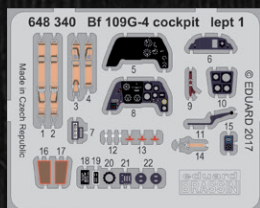
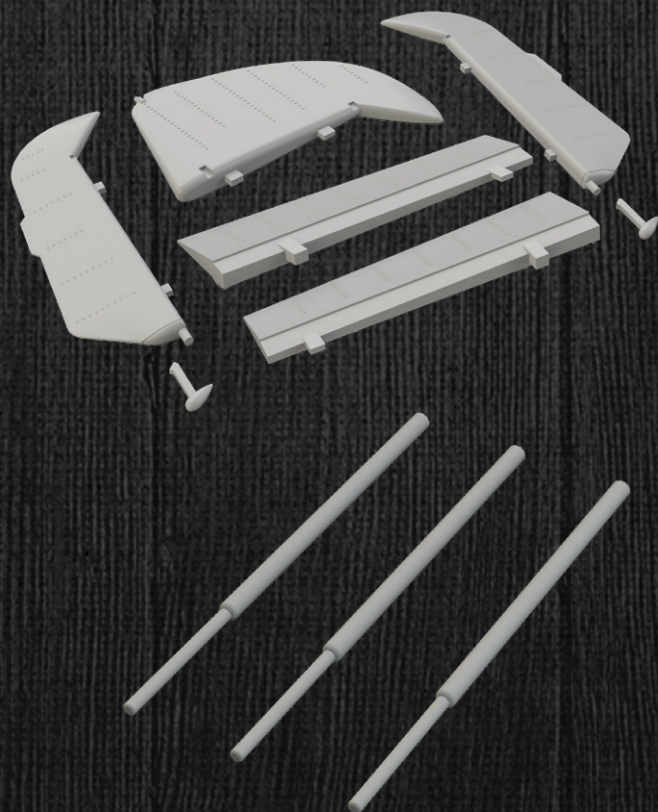
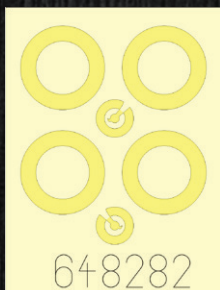



# TISKY BOXARTŮ

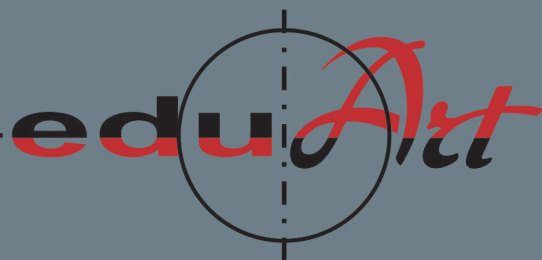

- Kvalitní obrazy ve velikost A2 (420 x 594 mm)
- UV ochrana na bílém vinylu 150g/m<sup>2</sup>
- Baleno do tvrdé obálky

pouze na [www.eduard.cz](http://www.eduard.cz)



Spittfire HF Mk.VIII

HF264, No. 22 Squadron, Foggia, Italy, early 1944

by Adam Trzaska



Eduard Model Accessories, 2018  
[www.eduard.com](http://www.eduard.com)



Spittfire LF Mk.IX

Model in flight - Luftwaffe Jagdgeschwader 101, 11 August 1941

by Peter Kocenda



Eduard Model Accessories, 2017  
[www.eduard.com](http://www.eduard.com)



P-51

10 Mustang II, 48th Fighter Group, 2nd Fighter Wing, 1945

by Adam Trzaska



Eduard Model Accessories, 2017  
[www.eduard.com](http://www.eduard.com)



Fw 190A-5

Major Josef Priller, Commanding Officer of Jagdgeschwader 26, English Channel, 3 May 1943

by Adam Trzaska



Eduard Model Accessories, 2018  
[www.eduard.com](http://www.eduard.com)



SE-5a

1918 SE-5a, 1st Squadron, 1st Royal Flying Wing, 1918

by Adam Trzaska



Eduard Model Accessories, 2017  
[www.eduard.com](http://www.eduard.com)



Bf 109G-6

1st Staffel, Jagdgeschwader 1, 1st Division, 1942

by Adam Trzaska



Eduard Model Accessories, 2017  
[www.eduard.com](http://www.eduard.com)

**NEW**



# HMS Belfast 1/350 Trumpeter

HMS Belfast 1/350 Trumpeter (53210)





# M113A ACAV 1/35 AFV Club

M113A ACAV 1/35 AFV Club (36377)  
M113A ACAV dashboard and seatbelts STEEL  
1/35 AFV Club (36378)





# He 111H-3 1/48 ICM

- He 111H-3 undercarriage 1/48 ICM (48497)
- He 111H-3 bomb bay 1/48 ICM (48498)
- He 111H-3 nose interior 1/48 ICM (49886)
- He 111H-3 radio compartment 1/48 ICM (49886)
- He 111H-3 interior 1/48 ICM (FE886) (Zoom)
- He 111H-3 seatbelts STEEL 1/48 ICM (FE887) (Zoom)
- He 111H-3 1/48 ICM (EX580) (Mask)

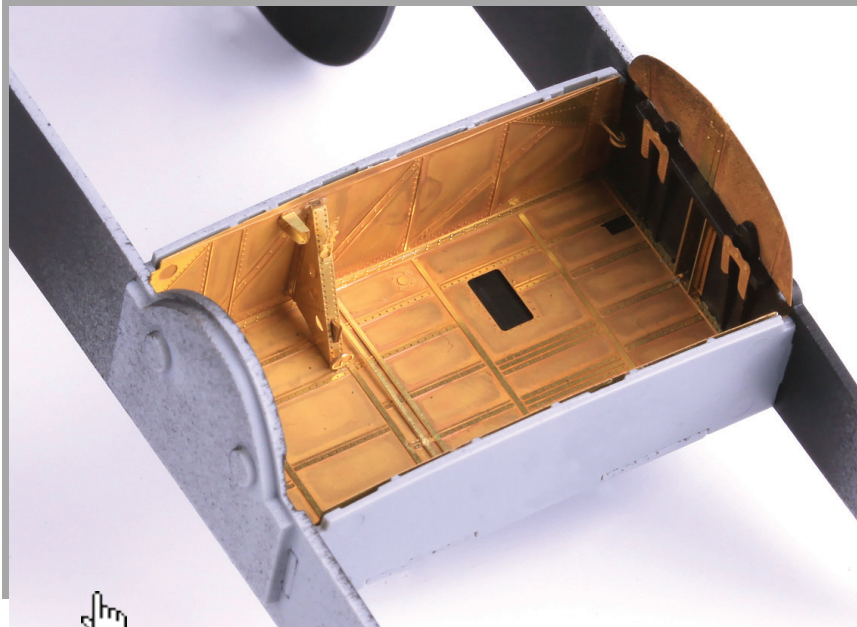
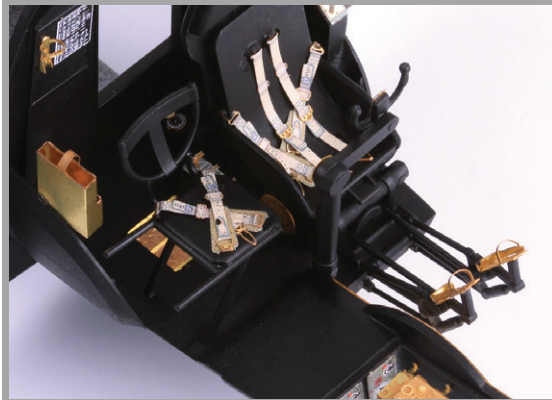
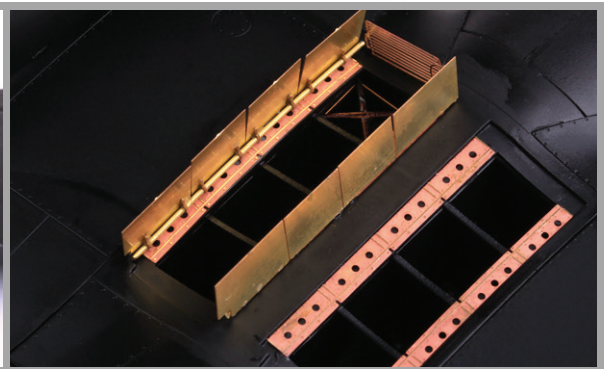



**B-2A bomb bay** 1/72 Modelcollect (72663)  
**B-2A undercarriage** 1/72 Modelcollect (72664)  
**B-2A** 1/72 Modelcollect (73624)  
**B-2A interior** 1/72 Modelcollect (SS624) (Zoom)  
**B-2A** 1/72 Modelcollect (CX504) (Mask)

# B-2A 1/72 Modelcollect

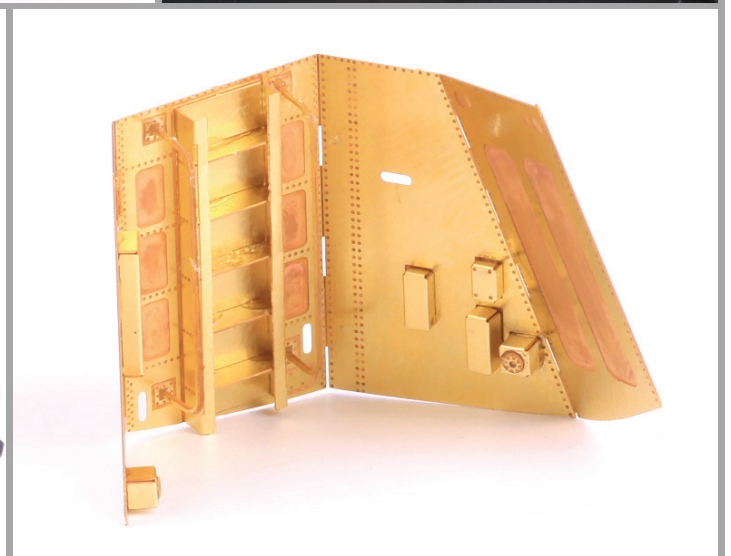
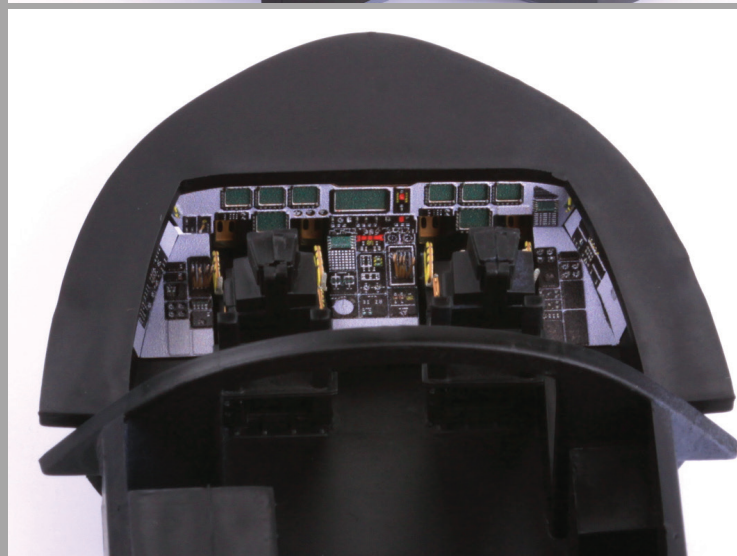
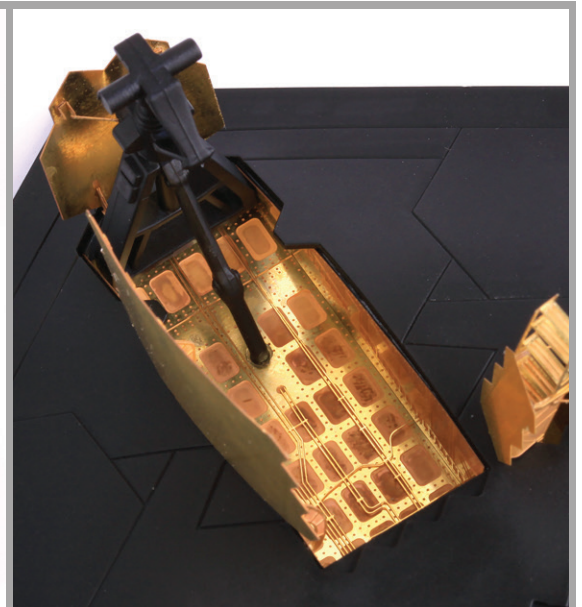
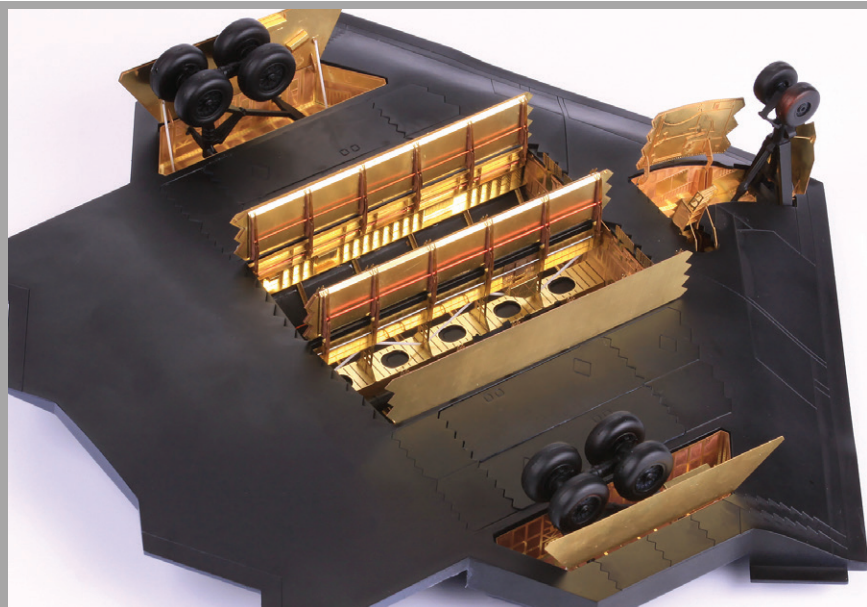



# F-15E 1/72 Academy



F-15E 1/72 Academy (73626)  
F-15E 1/72 Academy (SS626) (Zoom)  
F-15E 1/72 Academy (CX505) (Mask)





# FG.1 Phantom 1/72 Airfix

FG.1 Phantom 1/72 Airfix (73625)  
FG.1 Phantom 1/72 Airfix (SS625) (Zoom)  
FG.1 Phantom 1/72 Airfix (CX506) (Mask)





March 2018

**KITS**

7445	Avia Bk-534 Graf Zeppelin	1/72	Weekend edition
82143	Fw 190A-5 light fighter	1/48	ProfiPACK
8085	Fokker D.VIII	1/48	ProfiPACK
2121	Riders in the Sky 1944	1/72	Limited edition

**PHOTO-ETCHED SET**

53210	HMS Belfast	1/350	Trumpeter
32922	Remove Before Flight - Israel STEEL	1/32	
36377	M113A ACAV	1/35	AFV CLUB
36378	M113A ACAV dashboard & seatbelts STEEL	1/35	AFV CLUB
48947	He 111H-3 undercarriage	1/48	ICM
48948	He 111H-3 bomb bay	1/48	ICM
48949	Fw 190A-5	1/48	Eduard
48950	Fw 190A-5 landing flaps	1/48	Eduard
49886	He 111H-3 nose interior	1/48	ICM
49887	He 111H-3 radio compartment	1/48	ICM
72663	B-2A bomb bay	1/72	Modelcollect
72664	B-2A undercarriage	1/72	Modelcollect
73624	B-2A	1/72	Modelcollect
73625	FG.1 Phantom	1/72	Airfix
73626	F-15E	1/72	Academy
73627	Liberator GR Mk.V upgrade set	1/72	Eduard/Hasegawa

**ZOOMS**

33188	Sopwith 5F.1 Dolphin STEEL	1/32	WingNut Wings
FE886	He 111H-3	1/48	ICM
FE887	He 111H-3 seatbelts STEEL	1/48	ICM
SS624	B-2A	1/72	Modelcollect
SS625	FG.1 Phantom	1/72	Airfix
SS626	F-15E	1/72	Academy

**MASKS**

JX211	Sopwith 5F.1 Dolphin	1/32	WingNut Wings
EX580	He 111H-3	1/48	ICM
EX581	Bf 109G Erla canopy Tface	1/48	Eduard
EX582	Bf 109G classic canopy Tface	1/48	Eduard
CX504	B-2A	1/72	Modelcollect
CX505	F-15E	1/72	Academy
CX506	FG.1 Phantom	1/72	Airfix

**BIGED**

BIG5347	USS Iwo Jima LHD-7 pt.1	1/350	Trumpeter
BIG3386	I-16 Type 24	1/32	ICM
BIG3387	Mosquito B Mk.IX	1/32	HKM
BIG49187	Beaufighter Mk.VI	1/48	Tamiya
BIG72132	P-40N	1/72	Special Hobby
BIG72133	Fortress Mk.III	1/72	Airfix

**BRASSIN**

632121	Ammo belts 12,7 mm	1/32	
648384	AGM-154C Block II	1/48	
648385	GBU-38 Non-Thermally Protected	1/48	
648387	F-8E Crusader wheels	1/48	Hasegawa
648388	F-8E Crusader ejection seat	1/48	Hasegawa
648390	Fw 190A-5 cockpit	1/48	Eduard
648391	Fw 190A-5 engine	1/48	Eduard
648392	Fw 190A-5 fuselage guns	1/48	Eduard
648393	British Rocket Projectiles RP-3 60lb F.	1/48	
648394	British Rocket Projectiles RP-3 60lb S.A.P.	1/48	
672169	AN/ALQ-184 (short) ECM pod	1/72	
672170	B-24 wheels	1/72	Eduard/Hasegawa
672171	B-24 engines	1/72	Eduard/Hasegawa
672172	British 250lb depth charges	1/72	

**BIGSIN**

SIN63212	F4U-1D	1/32	Tamiya
SIN64842	Bf 109G-4 essential	1/48	Eduard





All sets included in this BIG ED are available separately, but with every BIG ED set you save up to 30%.

# BIG ED

## BIG5347 USS Iwo Jima LHD-7 pt.1 1/350 Trumpeter

Product Page

- 53184 USS Iwo Jima LHD-7 pt.3 superstructure 1/350
- 53185 USS Iwo Jima LHD-7 pt.4 railings & safety nets 1/350
- 53186 USS Iwo Jima LHD-7 pt.5 life rafts 1/350

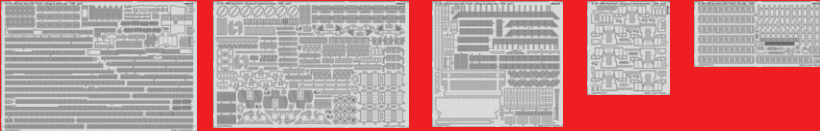

## BIG3386 I-16 Type 24 1/32 ICM

Product Page

- 33185 I-16 Type 24 seatbelts STEEL 1/32
- JX209 I-16 Type 24 1/32
- 32919 I-16 Type 24 1/32



## BIG3387 Mosquito B Mk.IX 1/32 HKM

Product Page

- 32417 Mosquito B Mk.IX exterior / engines 1/32
- 32418 Mosquito B Mk.IX bomb bay 1/32
- 32918 Mosquito B Mk.IX interior 1/32
- 33183 Mosquito B Mk.IX seatbelts STEEL 1/32
- JX208 Mosquito B Mk.IX 1/32

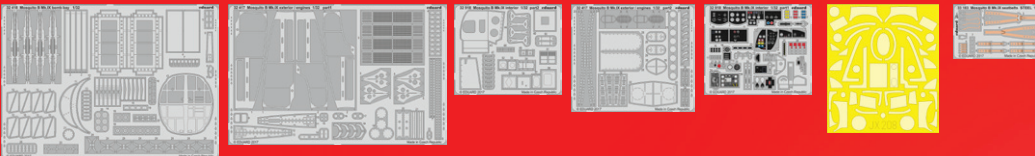

## BIG49187 Beaufighter Mk.VI 1/48 Tamiya

Product Page

- EX044 Beaufighter 1/48
- FE869 Beaufighter Mk.VI seatbelts STEEL 1/48
- 48938 Beaufighter Mk.VI landing flaps 1/48
- 49868 Beaufighter Mk.VI 1/48

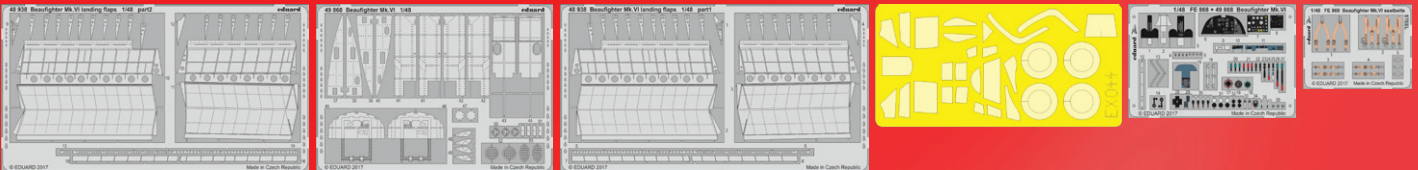

## BIG72132 P-40N 1/72 Special Hobby

Product Page

- 73619 P-40N 1/72
- 72658 P-40N landing flaps 1/72
- CX498 P-40N 1/72

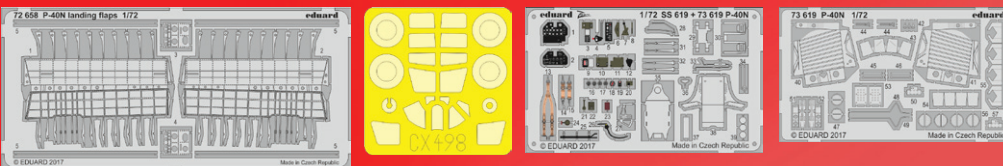

## BIG72133 Fortress Mk.III 1/72 Airfix

Product Page

- 73616 Fortress Mk.III front interior 1/72
- 73617 Fortress Mk.III rear interior 1/72
- 73567 B-17G cockpit interior
- 73568 B-17G seatbelts STEEL

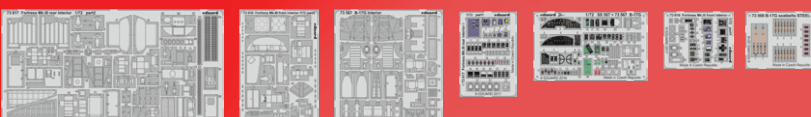



1/48

# MERSU



**Camo D**  
built by Petr Zatřepálek

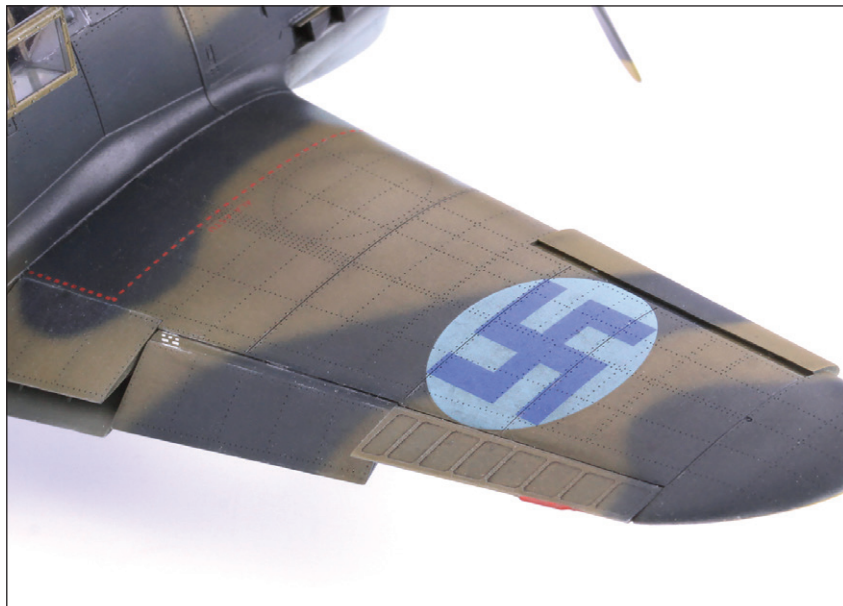



**Bf 109G-2, MT-230, kapteeni (Captain) Jaakko Puolakkainen, 2/HLeLv 28, Värtsilä, Finland, August 1944**

Jaakko Puolakkainen was born in St. Petersburg on September 29th, 1915. He received flying training in 1937-38 and on December 5th, 1939 was posted as vänrikki to LLv 28. On October 31st, 1943 was appointed as kapteeni to lead 2/LeLv 28. After the war Puolakkainen headed Koel (Testflight) and IlmavV (Air Force Signals Depot) and resigned from the duty as everstilutnantti on March 9th, 1963. Later he became a sales manager. Jaakko Puolakkainen died on June 25th, 1999. His wartime score was two confirmed and two damaged enemy aircraft.

During the war, ten Bf 109G-2s of the Finnish Air Force were camouflaged on top and side surfaces by black and olive green colour, the undersides were painted in RLM 65 colour. The circle under the Finnish swastikas had no longer been white on these repainted fighters, but was painted in RLM 65. The stencils had already been in Finnish language.

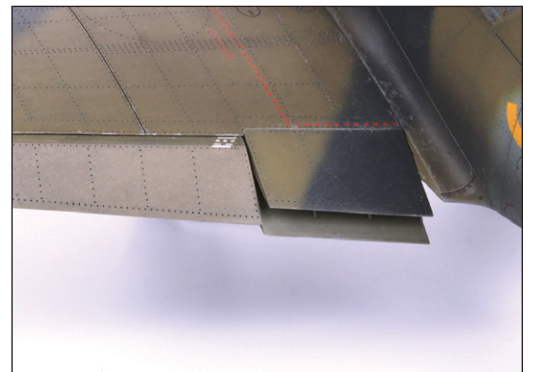
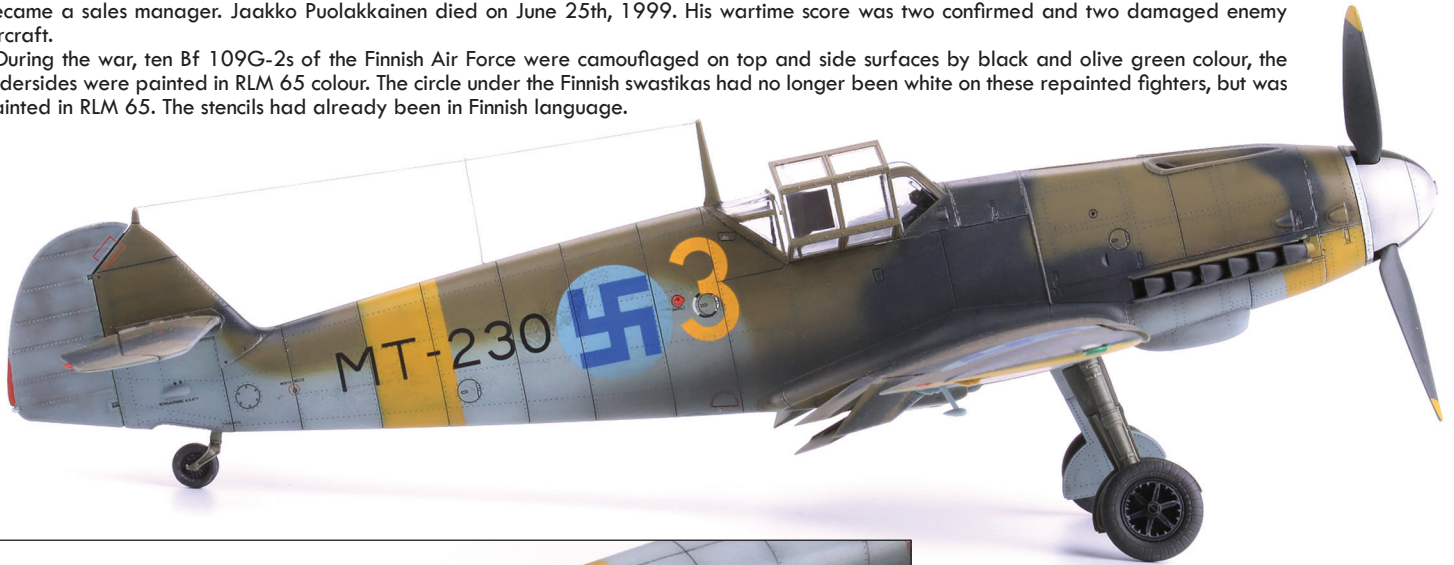

[Product Page](#)

Cat. No. 11114





MERSU T-shirt (M)

[Product Page](#)

MERSU T-shirt (L)

[Product Page](#)

MERSU T-shirt (XL)

[Product Page](#)

MERSU T-shirt (XXL)

[Product Page](#)

MERSU T-shirt (XXXL)

[Product Page](#)





# GBU-43/B MOAB

1/48



[Product Page](#)

Cat. No. 648348

built by Roman Hadaš

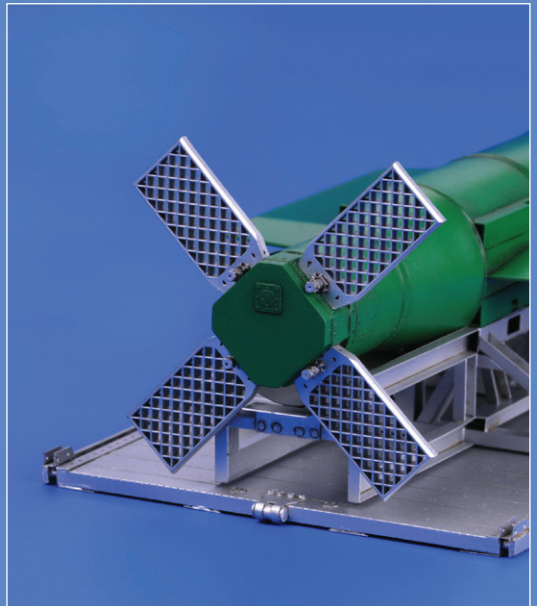



# Bf 109G-14



**Camo D**  
built by Jan Baranec

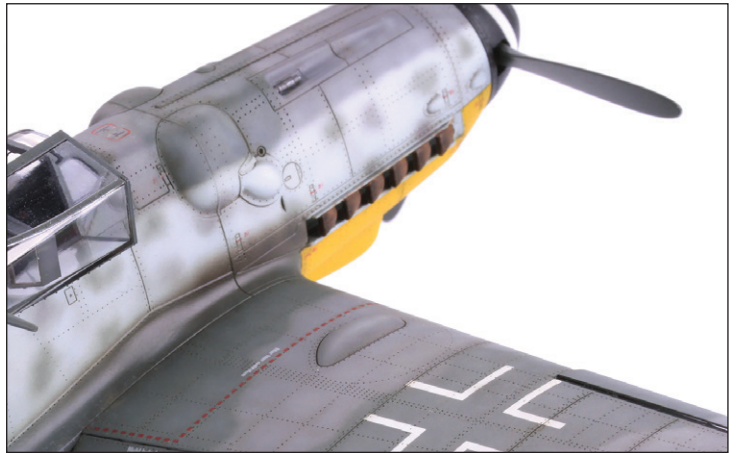



**Bf109G-14, Oblt. R. Schlegel, CO of 10./ JG 4, Jüterbog – Damm, Germany, March 1945**

Rolf Schlegel was born on June 14th, 1922 in Saxony. After his successful passing of the training he was sent to serve at 11./JG 2 that fought British pilots above the English Channel. He and his unit were soon moved over to African battlegrounds. Over there, Schlegel suffered injuries. After his recovery he continued at EKdo 16, which was a tester squadron testing the rocket-powered Me 163 aircraft. In summer 1944 he started to serve at JG 4, namely at its Sturmgruppe. This unit flew heavily armed Fw 190A-8/R2s. Later, he flew Bf 109s at III. Gruppe JG 4. Prior to the end of the war he was transferred to JG 7 flying jet-powered 262 Messerschmitt's. He shot down two enemy aircraft in combat.

The aircraft is bearing a typical camouflage of the later 109s produced in Erla factory in Leipzig. The plane's original marking is covered by fresh RLM 74 paint and the nose of the plane has JG 4 emblem. Wide stripes around the tail of the plane were typical for JG 4 fleet. These aircraft served as Defence of the Reich (Reichsverteidigung).

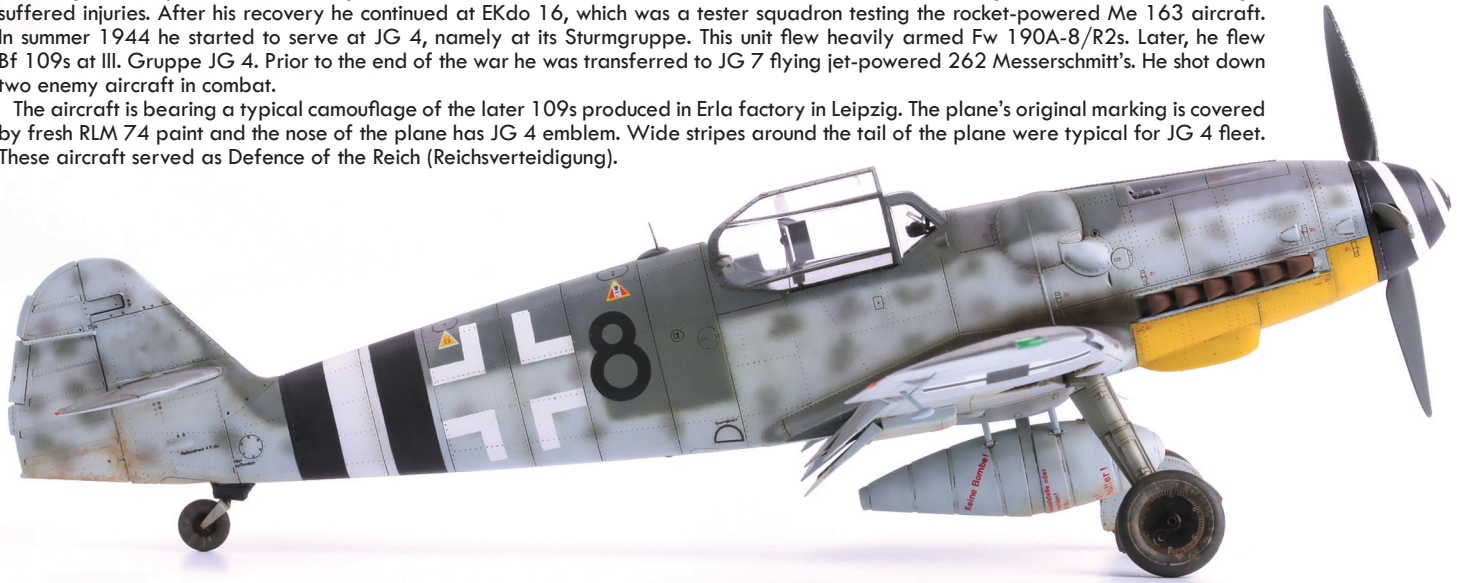

[Product Page](#)

Cat. No. 82118





**BUILT**

**1/48**

# Spitfire HF Mk.VIII

**ProfiPACK**  
edition



**Camo E**

built by Jan Novotný

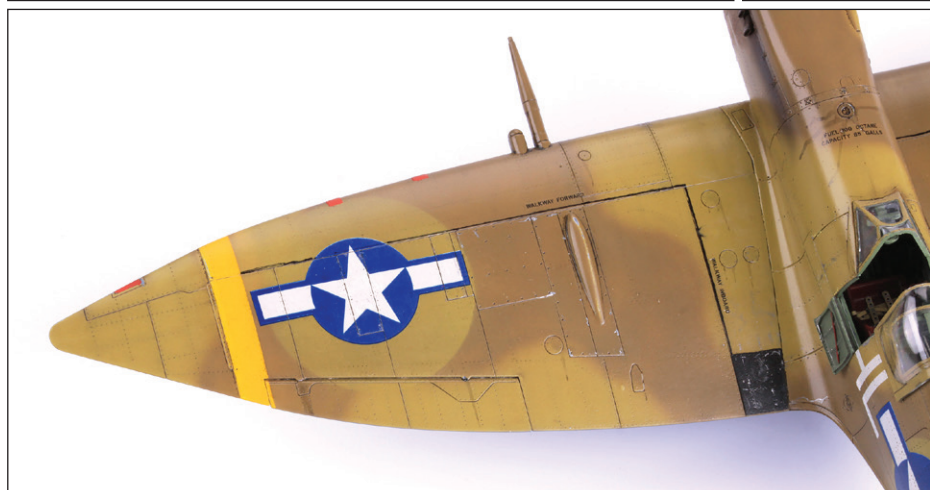



**308th Fighter Squadron, 31st Fighter Group, Castel Volturno, Italy, 1944**

308th Fighter Squadron was armed with P-39s and P-40s. The performance of these fighters was not enough to keep up with German opponents, which led to a relatively quick rearmament to Spitfires Mk.V. The Spitfires were used by 31st Fighter Group in a two-month heavy fights above northern France. Later the group was transferred to Gibraltar to use the base for take offs for Algeria as part of the disembarkation of the Allies in North Africa (Operation Torch). What followed were the fights against the forces of the Axis in North Africa. In May 1943 the 308th Fighter Squadron received Spitfires Mk.VIII, which were then used in the fights above Sicily and Italy. In March 1944, the Spitfires were replaced by P-51 Mustangs, which were used by 308th Fighter Squadron pilots till the end of war.



[Product Page](#)

Cat. No. 8287





NEXT MONTH....



BIG49188



BIG49189

## BIGED (April)

- BIG3388 P-51D-5 1/32 Revell
- BIG49188 Sea Hurricane Mk.Ib 1/48 Airfix
- BIG49189 Tomahawk Mk.II 1/48 Airfix
- BIG49190 A-4E 1/48 Hobby Boss
- BIG5348 USS Iwo Jima LHD-7 pt.2 1/350 Trumpeter
- BIG72134 Kittyhawk Mk.Ia 1/72 Special Hobby

## BRASSIN (April)



- 648386 GBU-38 Thermally Protected 1/48
- 648399 WGr.21 for Bf 109G-6 1/48 Tamiya
- 648400 Bf 109G-6 wheels 1/48 Tamiya
- 648401 Bf 109G-6 gun barrels 1/48 Tamiya
- 648402 Bf 109G-6 exhaust stacks 1/48 Tamiya
- 648403 Bf 109G gun pods 1/48 Tamiya
- 672173 Spitfire Mk. VIII / IX / XVI radiator fairings 1/72 Eduard
- 672174 Phantom FG.1 wheels 1/72 Airfix
- 672175 AGM-154A/C Block I 1/72
- 672177 B-24 bomb bay rocket projector 1/72 Eduard/Hasegawa
- 672178 B-24 turbochargers 1/72 Eduard/Hasegawa
- 672183 B-24 bomb bay doors 1/72 Eduard/Hasegawa



BIG49190

## BRASSIN (April)

- SIN63213 Fw 190A-8 PART I 1/32 Revell
- SIN63214 Fw 190A-8/R11 PART I 1/32 Revell
- SIN63215 Fw 190A-8 & A-8/R11 PART II 1/32 Revell

648386 GBU-38 Thermally Protected 1/48



648399 WGr.21 for Bf 109G-6 1/48 Tamiya

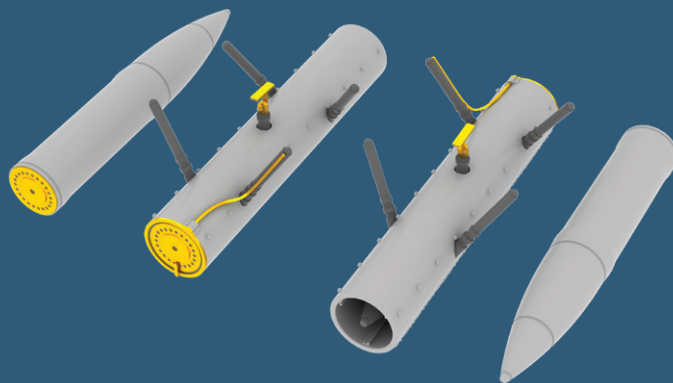



648400 Bf 109G-6 wheels 1/48 Tamiya



648401 Bf 109G-6 gun barrels 1/48 Tamiya

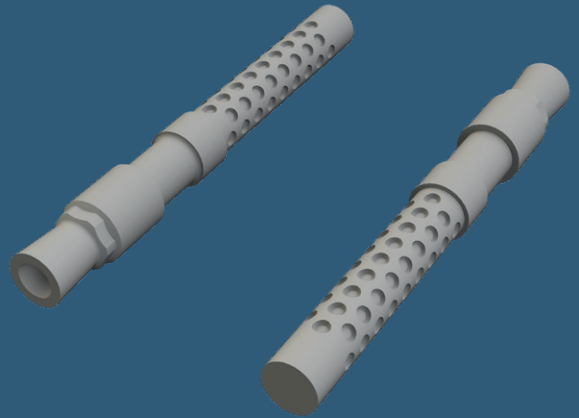

648402 Bf 109G-6 exhaust stacks 1/48 Tamiya

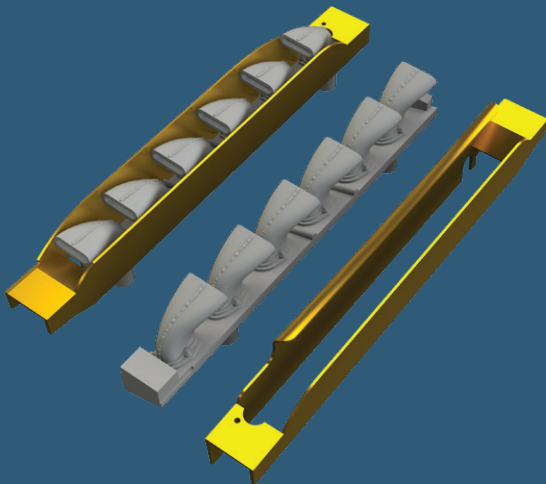

648403 Bf 109G gun pods 1/48 Tamiya

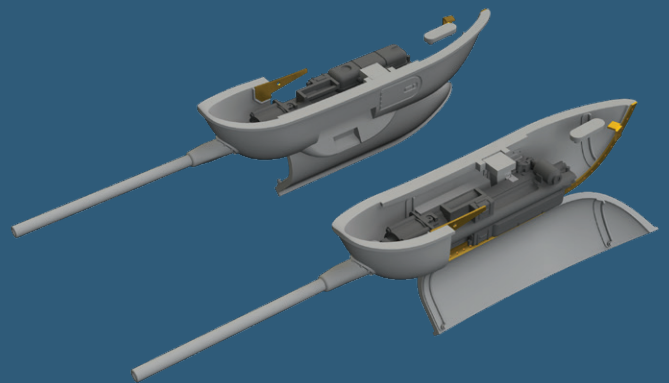

672173 Spitfire Mk. VIII / IX / XVI radiator fairings 1/72 Eduard

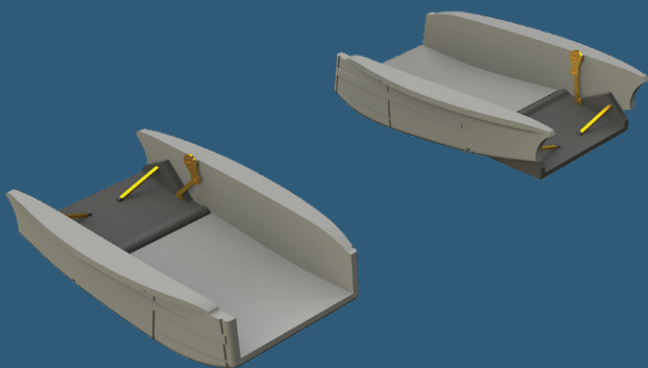

672174 Phantom FG.1 wheels 1/72 Airfix





672175 AGM-154A/C Block I 1/72

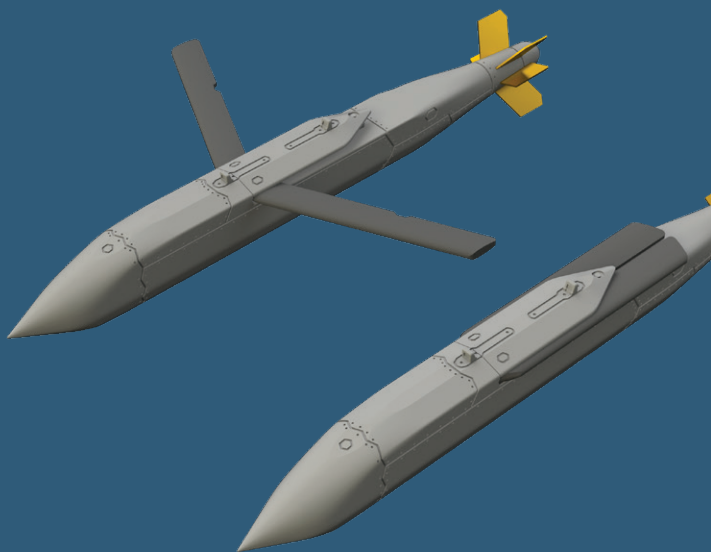

672177 B-24 bomb bay rocket projector 1/72 Eduard/Hasegawa

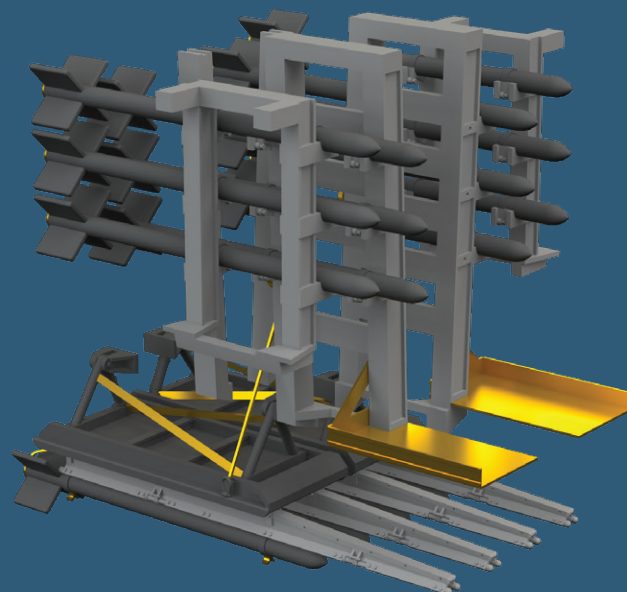

RIDERS IN THE SKY 1944 1/72

672178 B-24 turbochargers 1/72 Eduard/Hasegawa

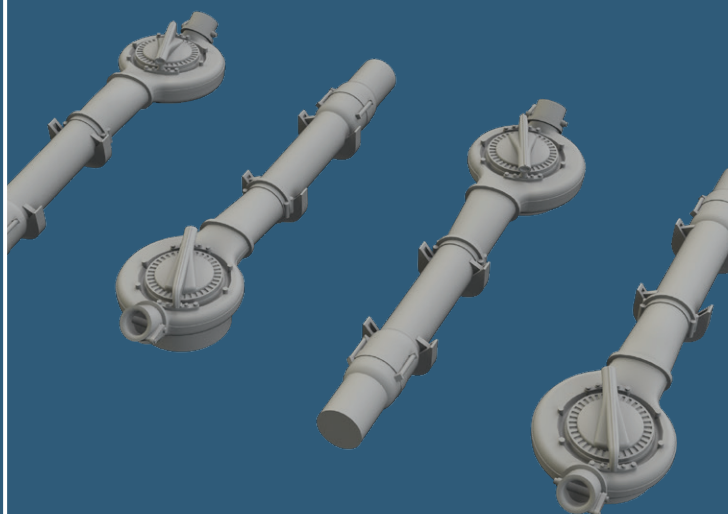

RIDERS IN THE SKY 1944 1/72

672183 B-24 bomb bay doors 1/72 Eduard/Hasegawa

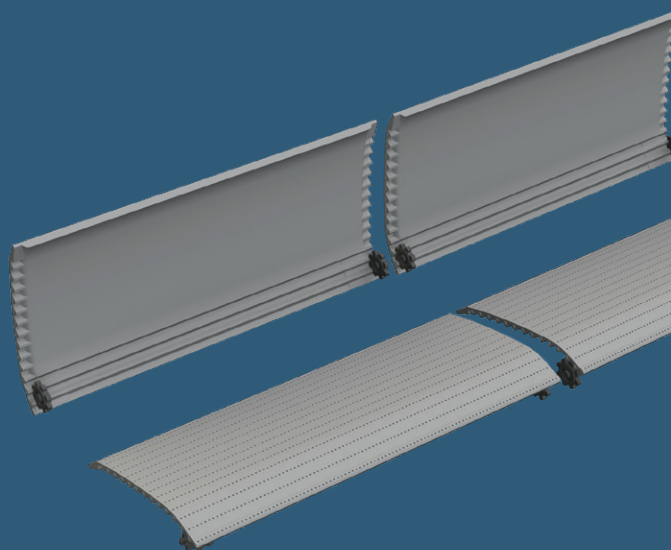

RIDERS IN THE SKY 1944 1/72



# ON APPROACH

APRIL 2018

## SIN63213 Fw 190A-8 PART I 1/32 Revell



Collection of 4 Brassin sets for Fw 190A-8 in 1/32 scale by Revell.

- cockpit,
- fuselage guns mount,
- painting mask,
- PE landing flaps.

All sets included in this BIG SIN are available separately, but with every BIG SIN set you save up to 30%.

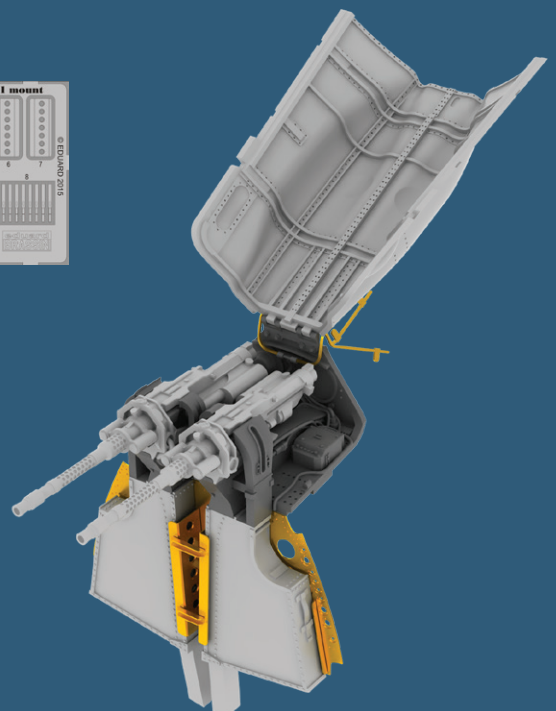
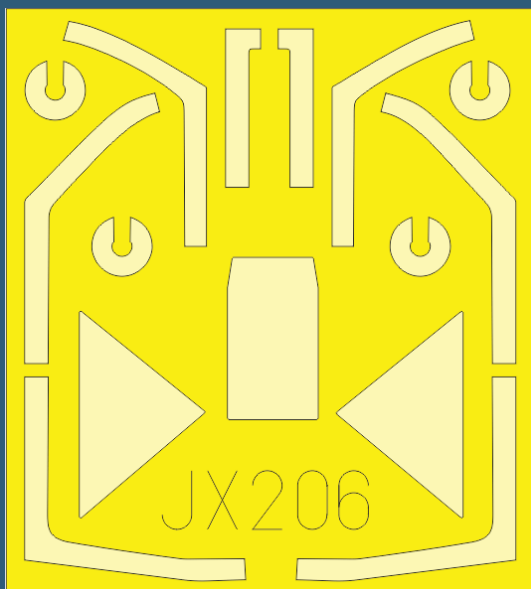
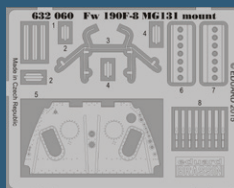
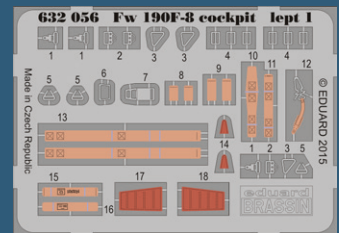
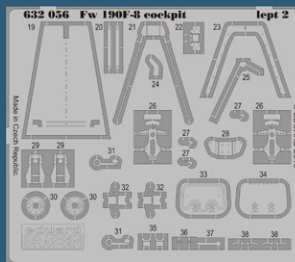
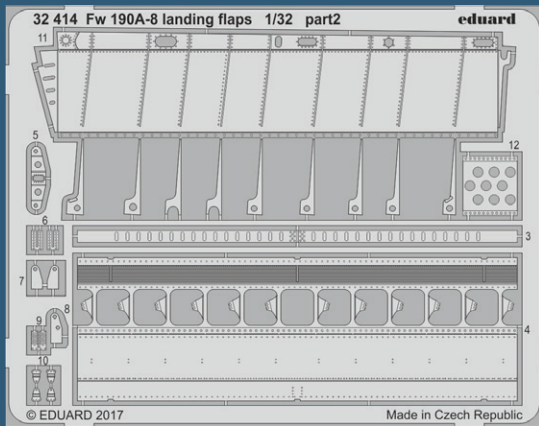
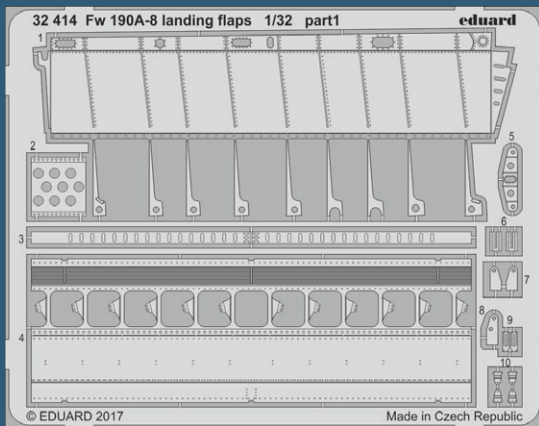
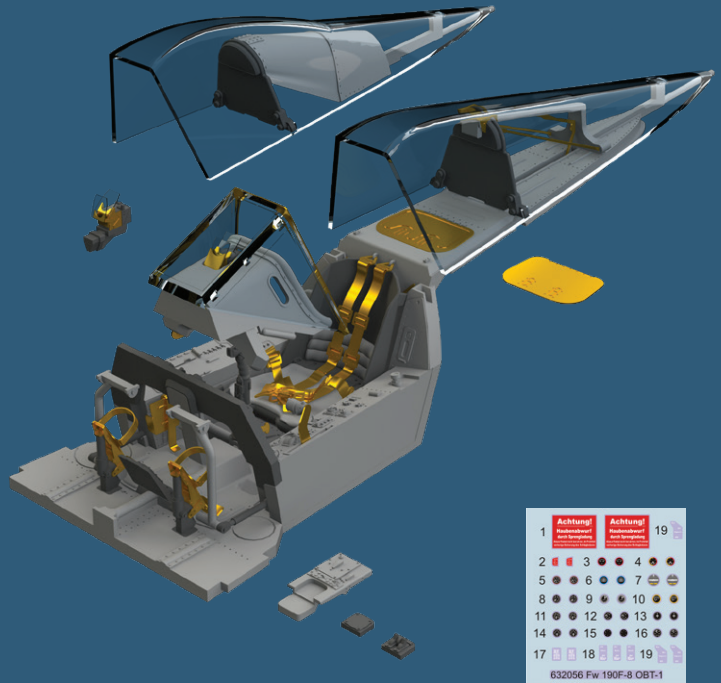

1	Achtung!	Achtung!	19
2	■	■	●
3	■	■	●
4	■	■	●
5	●	●	●
6	●	●	●
7	●	●	●
8	●	●	●
9	●	●	●
10	●	●	●
11	●	●	●
12	●	●	●
13	●	●	●
14	●	●	●
15	●	●	●
16	●	●	●
17	□	□	□
18	□	□	□
19	□	□	□

632056 Fw 190F-8 OBT-1



# ON APPROACH

APRIL 2018

SIN63214 Fw 190A-8/R11 PART I 1/32 Revell



Collection of 4 Brassin sets for Fw 190A-8/R11 in 1/32 scale by Revell.

- cockpit,
- fuselage guns mount,
- painting mask,
- PE landing flaps.

All sets included in this BIG SIN are available separately, but with every BIG SIN set you save up to 30%.

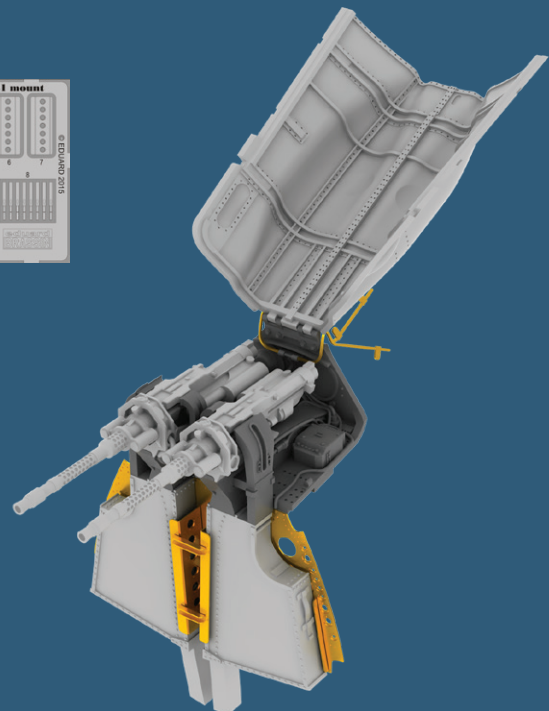
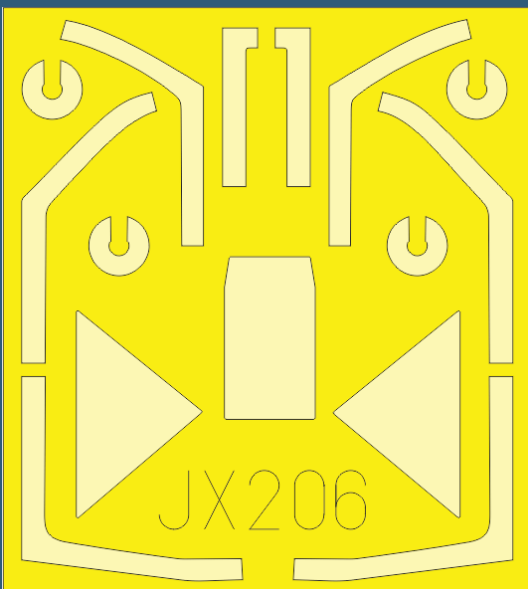
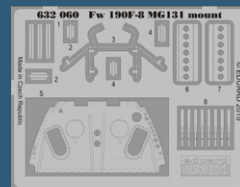
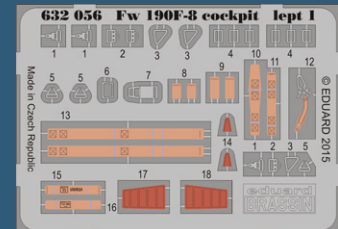
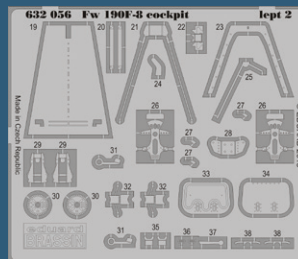
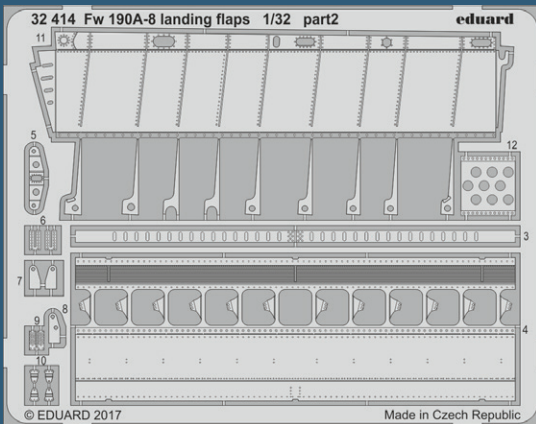
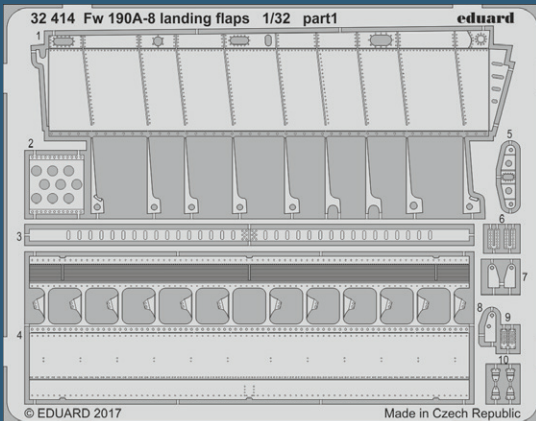
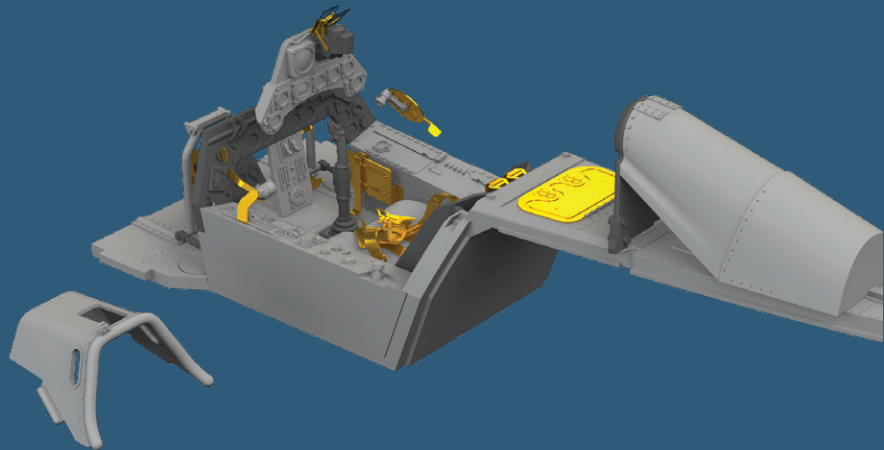



# ON APPROACH

APRIL 2018

## SIN63215 Fw 190A-8 & A-8/R11 PART II 1/32 Revell



Collection of 4 Brassin sets for Fw 190A-8 & A-8/R11 in 1/32 scale by Revell.

- wheels,
- undercarriage legs BRONZE,
- engine,
- propeller.

All sets included in this BIG SIN are available separately, but with every BIG SIN set you save up to 30%.

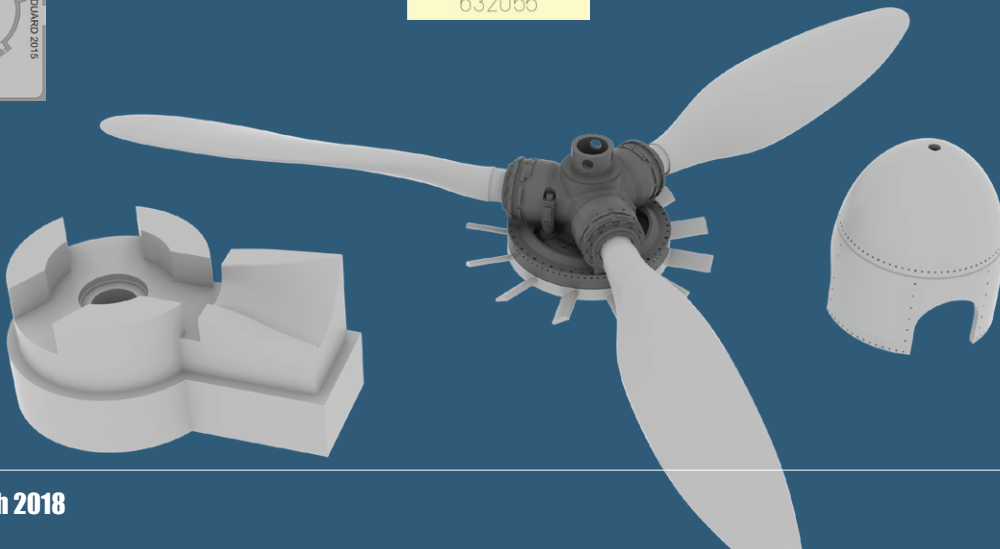
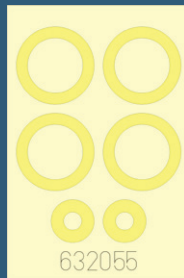
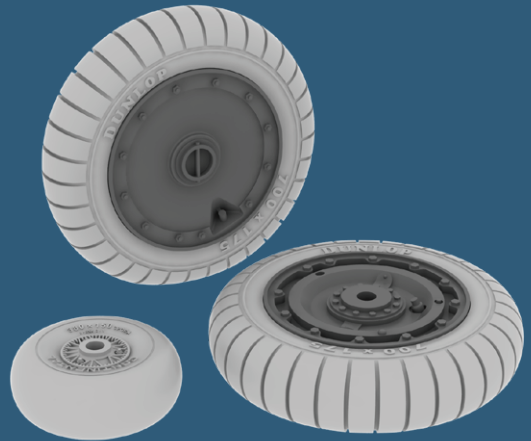
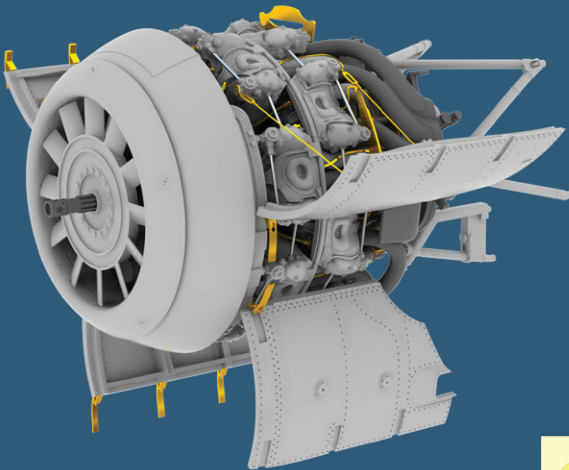
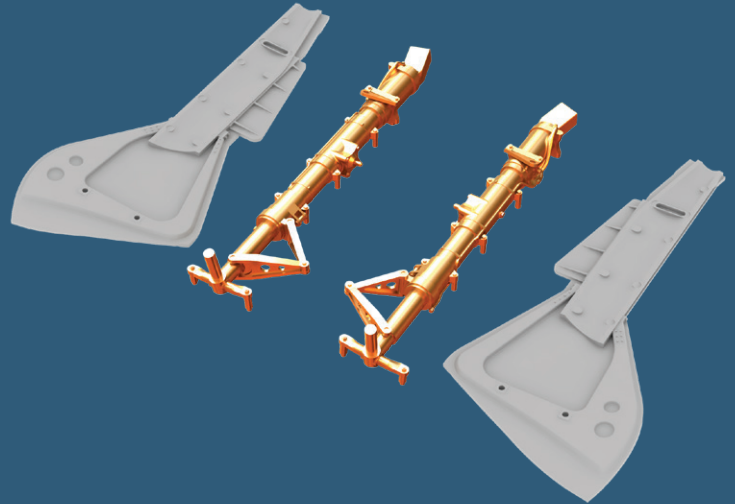





70128  
**Spitfire Mk.VIII**  
1/72

**ProfiPACK**  
edition

84147 1/48  
**Bf 109F-2** **WEEKEND**  
edition

8068 1/48  
**He 280**

**ProfiPACK**  
edition

11115 1/48  
**Vietnam**

**eduard**  
LIMITED EDITION



- |  |                   |
|--|-------------------|
| 53211 HMS Belfast railings               | 1/35 Trumpeter    |
| 53212 S-38 Schnellboot                   | 1/35 Italeri      |
| 53213 S-38 Schnellboot flag STEEL        | 1/35 Italeri      |
| 53214 S-38 Schnellboot hatches           | 1/35 Italeri      |
| 36379 Ferdinand                          | 1/35 Zvezda       |
| 36380 Ferdinand fenders                  | 1/35 Zvezda       |
| 32923 Remove Before Flight UK STEEL      | 1/32              |
| 48951 Su-17/22UM3K exterior              | 1/48 Kitty Hawk   |
| 48952 Su-17/22UM3K airbrakes             | 1/48 Kitty Hawk   |
| 49888 Su-17/22UM3K interior              | 1/48 Kitty Hawk   |
| 49890 Bf 109G-6                          | 1/48 Tamiya       |
| 72665 B-2A bomb bay doors                | 1/72 Modelcollect |
| 72666 Shackleton AEW.2 landing flaps     | 1/72 Airfix       |
| 72667 B-25C/D bomb bay                   | 1/72 Airfix       |
| 72668 FG.1 Phantom undercarriage         | 1/72 Airfix       |
| 73628 B-25C/D                            | 1/72 Airfix       |
| 73629 Shackleton AEW.2 cockpit interior  | 1/72 Airfix       |
| 73630 Shackleton AEW.2 fuselage interior | 1/72 Airfix       |

## APRIL 2018 / PE-SETS

### ZOOMY

- |                                    |                 |
|------------------------------------|-----------------|
| FE888 Su-17/22UM3K                 | 1/48 Kitty Hawk |
| FE889 Su-17/22UM3K seatbelts STEEL | 1/48 Kitty Hawk |
| FE891 Bf 109G-6                    | 1/48 Tamiya     |
| FE892 Bf 109G-6 seatbelts STEEL    | 1/48 Tamiya     |
| FE893 Bf 109F-2 Weekend            | 1/48 Eduard     |
| SS628 B-25C/D                      | 1/72 Airfix     |
| SS629 Shackleton AEW.2             | 1/72 Airfix     |